

Micro-Nano-Bio Diagnostic System for Food Pathogen Detection Revolutionizes Food Safety Management & Protects Consumers Health

Evangelos GOGOLIDES^a, Angeliki TSEREPI^a, Gerhard JOBST^b, Jean-Michel FRIEDT^c, David RABUS^c, Bruno DUPUY^d, Zuzana BILKOVA^e, Stephanie Descroix^f, Jean-Louis VIOVY^f, George PAPADAKIS^g and Electra GIZELI^{g, h, 1},

^a *Institute of Nanoscience and Nanotechnology, NCSR-Demokritos, Patriarhou Gregoriou Str., Aghia Paraskevi 15310, Greece*

^b *Jobst Technologies GMBH, 4B Engesserstrasse Freiburg 79108, Germany*

^c *SENSeOR SAS, 18Temis Innovation, rue Alain Savary 25000 Besançon, France*

^d *Inst. Pasteur, 25-28 Rue du Docteur Roux, Paris Cedex 15, 75724 France*

^e *University of Pardubice, 573 Studentska, Pardubice 532 10, Czech Republic*

^f *Institut Curie, 26 Rue d'Ulm, Paris 75231, France*

^g *Institute of Molecular Biology and Biotechnology-FORTH, 100 N. Plastira Str, Heraklion, 70013, Greece*

^h *Dept. of Biology, Univ. of Crete, Vassilika Vouton, 71409, Greece*

Abstract. The development of integrated, fast and affordable platforms for pathogen detection is an emerging area where a multidisciplinary approach is necessary for designing microsystems employing miniaturized devices; these new technologies promise a significant advancement of the current state of analytical testing leading to improved healthcare. In this work, the development of a lab-on-chip microsystem platform for the genetic analysis of *Salmonella* in milk samples is presented. The heart of the platform is an acoustic detection biochip, integrated with a microfluidic module. This detection platform is combined with a micro-processor, which, alongside with magnetic beads technology and a DNA micro-amplification module, are responsible for performing sample pre-treatment, bacteria lysis, nucleic acid purification and amplification. Automated, multiscale manipulation of fluids in complex microchannel networks is combined with novel sensing principles developed by some of the partners. This system is expected to have a significant impact in food-pathogen detection by providing for the first time an integrated detection test for *Salmonella* screening in a very short time. Finally, thanks to the low cost and compact technologies involved, the proposed set-up is expected to provide a competitive analytical platform for direct application in field settings.

Keywords. Lab-on-Chip; food safety; micro-nano-bio system; integrated platform

Introduction

Food safety is a top priority for ensuring worldwide citizens' good-health and food-producers reliability. Currently, foodborne illness outbreaks in Europe and the USA, due to infectious diseases spread through food or beverages, account for over 120 million cases of people being infected annually with a typical hospitalization rate of 0.5%. Numbers reported by the European Food Safety Authority and European Centre

¹ Corresponding Author.

for Disease Prevention and Control for 2010 were 5,262 food-borne outbreaks, leading to several thousands of hospitalizations and even deaths. In addition to posing some serious health risks, foodborne diseases are extremely costly accounting for several billion dollars paid annually in direct medical expenses and lost productivity.

With over 270,000 companies, the food industry is one of the largest European manufacturing sectors, providing employment to more than 4 million people and having an annual turnover of 956 million Euros [1]. Foodborne outbreaks have a significant impact on consumers' trust for food producers and manufacturers. Given the above, it is now an urgent need to introduce a paradigmatic change in food control and testing, so that food production companies can provide reliable quality control that will establish consumers' faith in their products.

The key challenges for better food safety management are to develop methods that ensure fast, sensitive, cost effective, simple and efficient food quality control. Towards this end, nano-micro-bio integrated systems can provide a reliable solution for both the consumers and food industry. European FP-7 funded LoveFood and its follow up Horizon2020 LoveFood2Market projects are dedicated to the development of such a system by bringing together scientific and technological innovations to produce a fully integrated platform for foodborne pathogen analysis.

1. Current and future methods for foodborne pathogen detection

1.1 State-of-the-art

Food industry needs sensitive techniques that can achieve the detection limits imposed by the EC; these typically vary from 1 bacterium in 25 gr (*Salmonella*) to 10 bacteria in 1 gr (*Enterobacteriaceae*) of sample. As a result, a bottleneck in developing relevant methodologies is imposed by the need to include a culture/pre-enrichment step to amplify and subsequently detect as little as 1 bacterium, if present. Currently, culture colony counting is the standard method used for food-pathogen detection, following plating and cultivation. The method is highly sensitive and specific, can discriminate between dead and vital cells and is inexpensive (Fig. 1A); however, it is very long and labor-intensive. Alternative analytical methods based on innovative molecular biology tools have also been developed and validated exploiting antibodies (ELISA) or nucleic acids (PCR) [2, 3]. These techniques also require a pre-enrichment step prior to specific biomarker analysis, which however can be shorter than that employed in microbiological methods due to the high sensitivity of biomarkers' detection. A key aspect in comparing all available techniques is balancing analysis time with price and level of simplicity. A typical microbiology method [4] costs as little as 3€ per test but requires incubation steps that last overall 3 days before cells can be visually inspected by a trained personnel under the microscope. Immunological tests [5] for *Salmonella* may require up to 48 hrs for pre-enrichment, while detection is performed automatically within 1 hr, with a typical cost of around 10€ per test and 20K€ for the electronics reader. Genetic test for *Salmonella* include 10-16 hrs of enrichment followed by a 3 hrs procedure which involves cell lysis, DNA extraction and PCR amplification and detection (Fig. 1B), with prices being around 10€ per test and 30K€ for a real time PCR. Molecular biology tests include both off-chip sample preparation procedures, i.e., sample pre-enrichment (ELISA and PCR) and cells lysis and DNA

isolation (PCR), and on-chip detection (spectrophotometer, qPCR), therefore, they are semi-automatic and require the attention of a trained personnel.

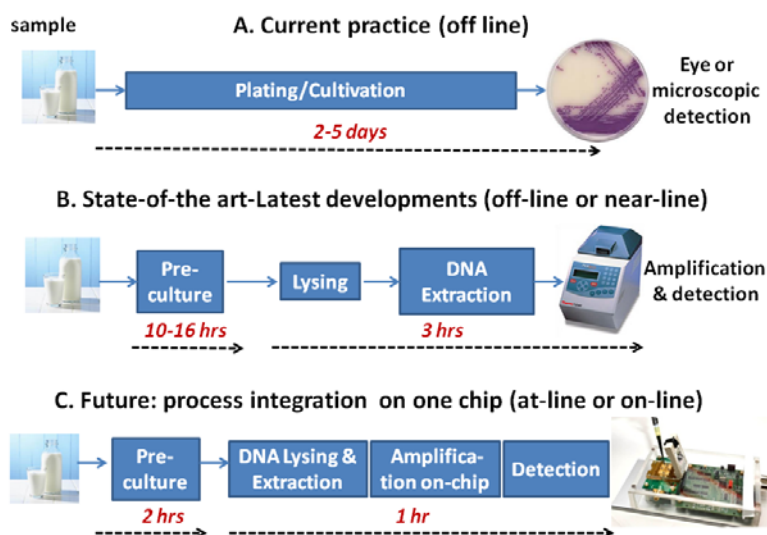

Figure 1. Schematic representation of currently available foodborne pathogen detection systems based on microbiology principles (A), molecular biology methods (B) or the LoveFood integrated platform.

1.2 Beyond the state-of-the-art

To address food safety issues effectively and prevent the possibility of releasing contaminated food from production sites, it is obvious that industry needs a new generation of sensitive, rapid, and cost-effective analytical methods. In terms of sensitivity, currently PCR presents the ultimate method, since in theory it can detect the presence of a single DNA copy. In addition, further decrease of the analysis time would greatly benefit from (i) the use of ultra sensitive techniques that will reduce significantly the pre-culture time, and (ii) the integration of all sample pre-treatment and DNA detection steps in a single module for on-chip automatic analysis. LoveFood and its follow up LoveFood2Market projects are dedicated towards the development of a system which includes a portable measuring unit combined with a disposable cartridge, the latter being able to perform (1) cell capture and lysis, and (2) DNA isolation, amplification and detection in a single step and without the need of trained personnel (Fig. 1C). In addition, we are aiming for a short pre-culture time leading to a total analysis time of less than 4 hrs and a total cost which will be competitive to that of current molecular biology food-analysis products.

2. LoveFood integrated analysis platform

2.1 Technological and scientific achievements of LoveFood project

The proposed platform was created with the aim of providing an autonomous lab-on-chip system that will satisfy the need for simple, sensitive, fast and inexpensive analysis. LoveFood solution capitalizes on several innovative concepts, which have already been proven to meet the required criteria for fast, low cost and highly sensitive analysis of pathogens in food. These concepts are gathered on a credit-card size Lab-on-Chip platform, where all necessary steps for bacteria detection are performed on several chips. Specifically, bacteria capture and lysis (Fig. 2 a/ top image), DNA extraction (Fig. 2a, 2nd from top) and amplification (Fig. 2a, 3rd from top) and finally pathogenic-DNA detection (Fig. 2a, last) can be performed without the need for skilled personnel or large, lab-based dedicated equipment. Handling of the liquid sample is achieved thanks to microfluidics while detection exploits acoustic wave biochips exploiting a Love wave device. An electronics unit comprising the necessary temperature, fluidics and acoustic control elements, gathered in a box the size of a medium briefcase, is designed to operate for acoustic sensing.

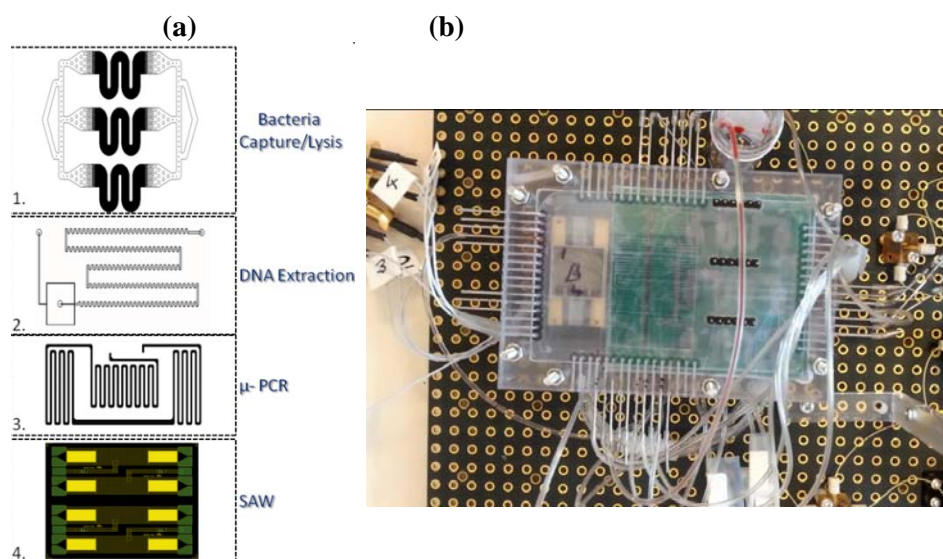

Figure 2. (a) The individual modules of the LOC cartridge comprise the following modules 1. cell capture and lysis; 2. DNA extraction (purification); 3. μ PCR; and, 4. acoustic bochip. (b) Picture of the assembled LoC prototype with the integrated modules.

2.2 Innovation and performance

The platform relies on several technological and scientific advancements; It employs a patented method for achieving cell capture and DNA isolation on chip, based on the use of a nanopatterned plasma-activated plastic module [6]; this module was shown to be able to achieve 100% efficiency in capturing

specifically few *Salmonella* bacteria (1-100) even in the presence of thousands of non-specific cells (*E.coli*), and in purifying their DNA. Nucleic acid amplification was further demonstrated on chip by using a continuous flow μ PCR or isothermal modules [7, 8], both fabricated by mass production amenable technologies on PCB or FPC substrates; in the latter case, copper facilitates the incorporation of on-chip microheaters, defining the thermal zones necessary for enzymatic amplification. A ground-breaking idea regarding DNA detection was employed during the acoustic detection of double stranded DNA amplicons based on their size (rather than mass) (9, 10). This patented approach was shown to be able to acoustically detect target *Salmonella* DNA produced in the presence of an internal control gene. An amazing sensitivity was demonstrated by showing acoustic detection of as little as 5 bacteria in unpurified PCR cocktail. Employing a microfluidic module has shown efficient operation of the system for achieving *Salmonella* analysis on-chip.

2.3 Partners' role

LoveFood and its follow up project LoveFood2Market involve a truly multidisciplinary approach, where expertise in biophysics, molecular biology, micro/nano engineering and IT are brought together by a strong team of experts in each field. Partners' defined roles in the project are described below:

- SENSEOR, an SME with expertise on acoustic sensors and systems, is developing the electronics hardware and software of the final product, as well as designing and manufacturing acoustic devices.
- Jobst Technologies, another industrial partner with expertise in microfluidics and LoC technologies, is developing the LoC to world interface of the final prototype.
- NCSR-D, a world expert research group in plasma nanotechnologies, is involved in the creation of plastic chips (nanotextured) for bacteria capture and lysis, as well as DNA purification and amplification purposes.
- FORTH, a research partner known for its pioneering work in acoustic wave biosensors, is developing genetic assays for acoustic-based *Salmonella* detection.
- Pardubice University, an academic partner, is contributing unique expertise in immunoseparation and micro/nano- particles functionalization.
- Pasteur Institute, a research-based partner, is contributing unique expertise in microbiology and cell culture optimization
- Finally, Curie also a research partner is contributing their world-recognized expertise in microfluidics handling and nano/micro-purification engineering.

2.4 Looking into the future

The integrated LOC LoveFood platform is expected to have a big impact in food-analysis by providing new opportunities to improve citizens' healthcare.

Moreover, in addition to the competitive performance criteria described above, is aligned with future market trends. It provides an autonomous system, where no additional reagents will be necessary other than those stored in the disposable LOC cartridge. It employs inexpensive technologies, taking advantage of cheap materials and production processes. Finally, the system can be easily operated using a smart-phone based application, enabling small manufacturers as well as the wide public to carry out food-analysis tests per will. Especially, the use of acoustic chips as the sensing element provides enormous opportunities for smart-phone applications where data could be collected with a mobile phone at a remote field testing site and transferred instantaneously to a central office where decisions are taken. Innovations and advancements demonstrated within LoveFood and proposed to reach the market with LoveFood2Market have potential to be used in all food samples, i.e., dairy products (cheese, yogurt etc.), fish, meat etc. Finally, the proposed integrated genetic assay for microbiological detection could have impact in providing solution to other problems of the food sector: tests for quality food control in terms of authentication (for example, the recent “horse meat crisis”) and optimization of cleaning operations by controlling microbiological hazards are areas where the LoveFood system could provide a viable solution and become a competitive product.

References

- [1] http://www.fooddrinkeurope.eu/loads/publications_document/temp_file_Summary_FDE_datatrends_page_par_page1.pdf
- [2] Gopinath S.C.B. et al., Bacterial detection: from microscope to smartphone, *Biosens Bioel* **60** (2014), 332-342
- [3] Arora K., Recent developments in bio-molecular electronics techniques for food pathogen, *Anal Chim Acta* **568**(1-2) (2006), 259-274
- [4] http://www.birolab.dk/uploads/pdf/food%20safety/PPP_METHODODE_IRIS_Salmonella_BIOKAR_23-10-2012%20angl.pdf
- [5] <http://www.biomerieux-industry.com/food/vidas-salmonella-detection>
- [6] K. Tsougeni, G. Papadakis, M. Gianneli, A. Grammoustianou, V. Constantoudis, B. Dupuy, P. Petrou, S. Kakabakos, A. Tserepi, E. Gizeli and E. Gogolides, Plasma nanotextured polymeric lab-on-a-chip for highly efficient bacteria capture and lysis, *Lab on a Chip*, (2015) DOI: 10.1039/C5LC01217A
- [7] D. Moschou, N. Vourdas, G. Kokkoris, G. Papadakis, J. Parthenios, S. Chatzandroulis, A. Tserepi, All-plastic, low-power, disposable, continuous-flow PCR chip with integrated microheaters for rapid DNA amplification, *Sensors and Actuators B* **199** (2014), 470-478
- [8] G. Kaprou, G. Papadakis, D. Papageorgiou, G. Kokkoris, V. Papadopoulos, I. Kefala, E. Gizeli, A. Tserepi, Miniaturized devices for isothermal DNA amplification addressing DNA diagnostics, *Microsyst. Technol.* (2015) DOI 10.1007/s00542-015-2750-x
- [9] G. Papadakis and E. Gizeli, Screening for mutations in BRCA1 and BRCA2 genes by measuring the acoustic ratio with QCM, *Analytica Methods* **6**(2) (2014), 363-371
- [10] G. Papadakis, A. Tsortos, A. Kordas, I. Tiniakou, E. Morou, J. Vontas, D. Kardassis and E. Gizeli, Acoustic detection of DNA conformation in genetic assays combined with PCR, *Scientific Reports* **3** (2013), 2033