

# Dynamic characterization of a micro-fabricated heat flux sensor

Kharkwal.H<sup>(1,2\*)</sup>, Gavignet.E<sup>(2)</sup>, Euphrasie.S<sup>(1)</sup>, Shah.S<sup>(2)</sup>, Hamieh.A<sup>(2)</sup>, Barthès.M<sup>(1)</sup>, Tadriss.L<sup>(3)</sup>, Lanzetta.F<sup>(2)</sup>

(1) Université Marie et Louis Pasteur, CNRS, institut FEMTO-ST, F-25000 Besançon, France,

(2) Université Marie et Louis Pasteur, CNRS, institut FEMTO-ST, F-90000 Belfort, France,

(3) Université d'Aix-Marseille, CNRS, IUSTI, Marseille, France



## 1. INTRODUCTION / CONTEXT

ANR TraThI :

- Aim** : To measure **heat transfer** at wall-fluid interfaces during **pool boiling**
- Focus** → **ONB** (without the effect of other bubbles)
- Require** : **Boiling-meter ( $\mu$ -BM)**

**Create** : one single bubble  
**Sensors** : heat flux ( $q$ ) and wall temperature ( $T_w$ )

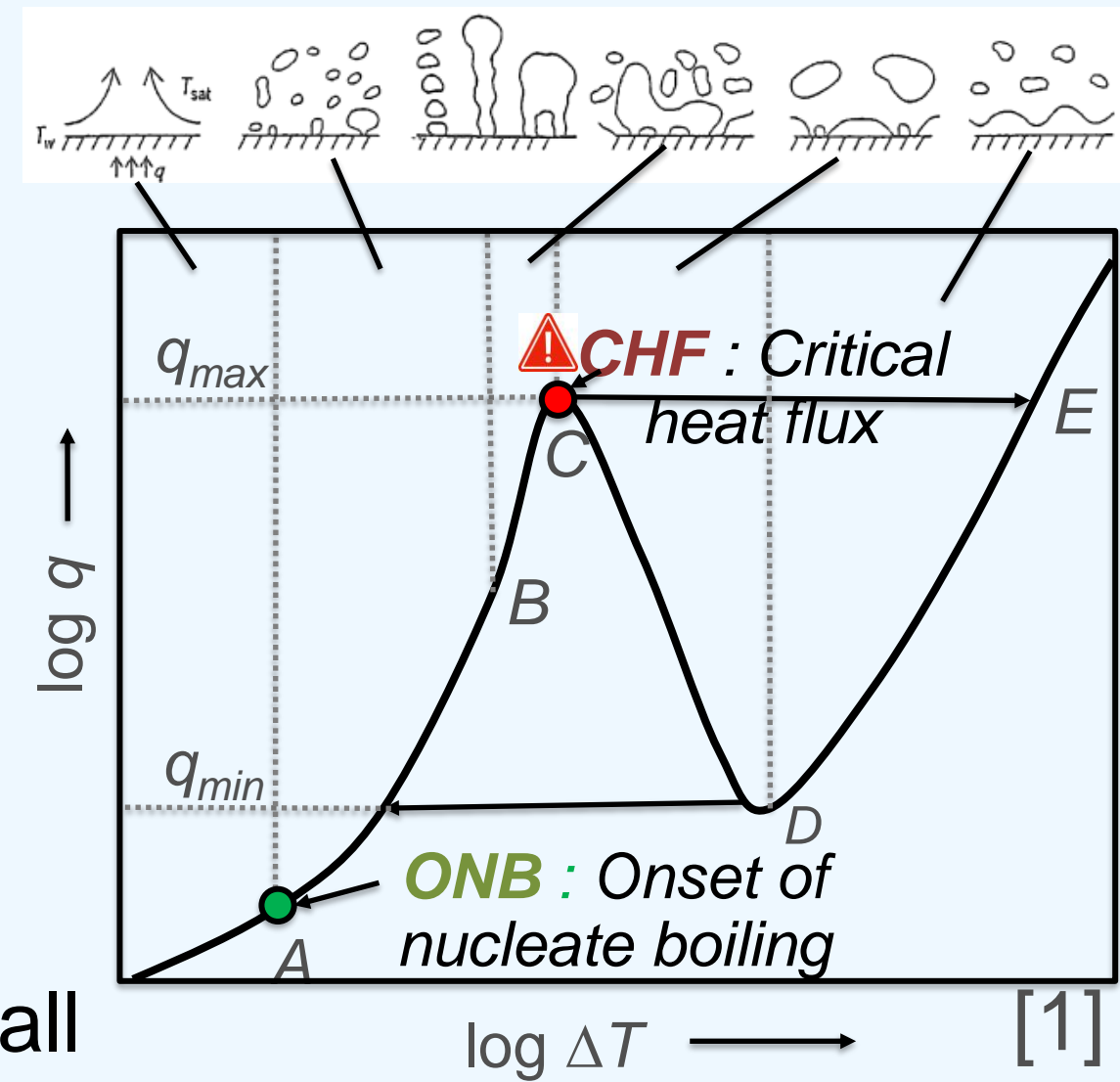

## 2. DESIGN & MICROFABRICATION

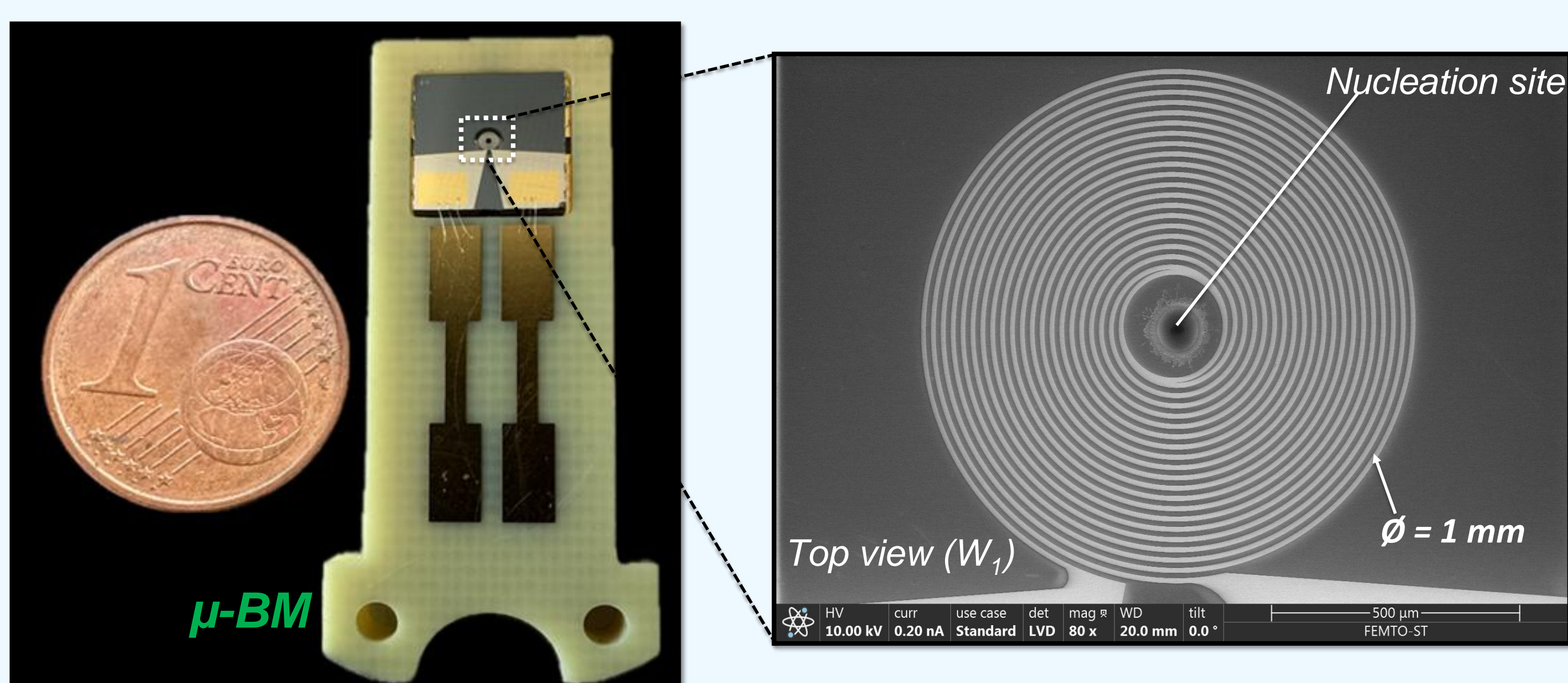
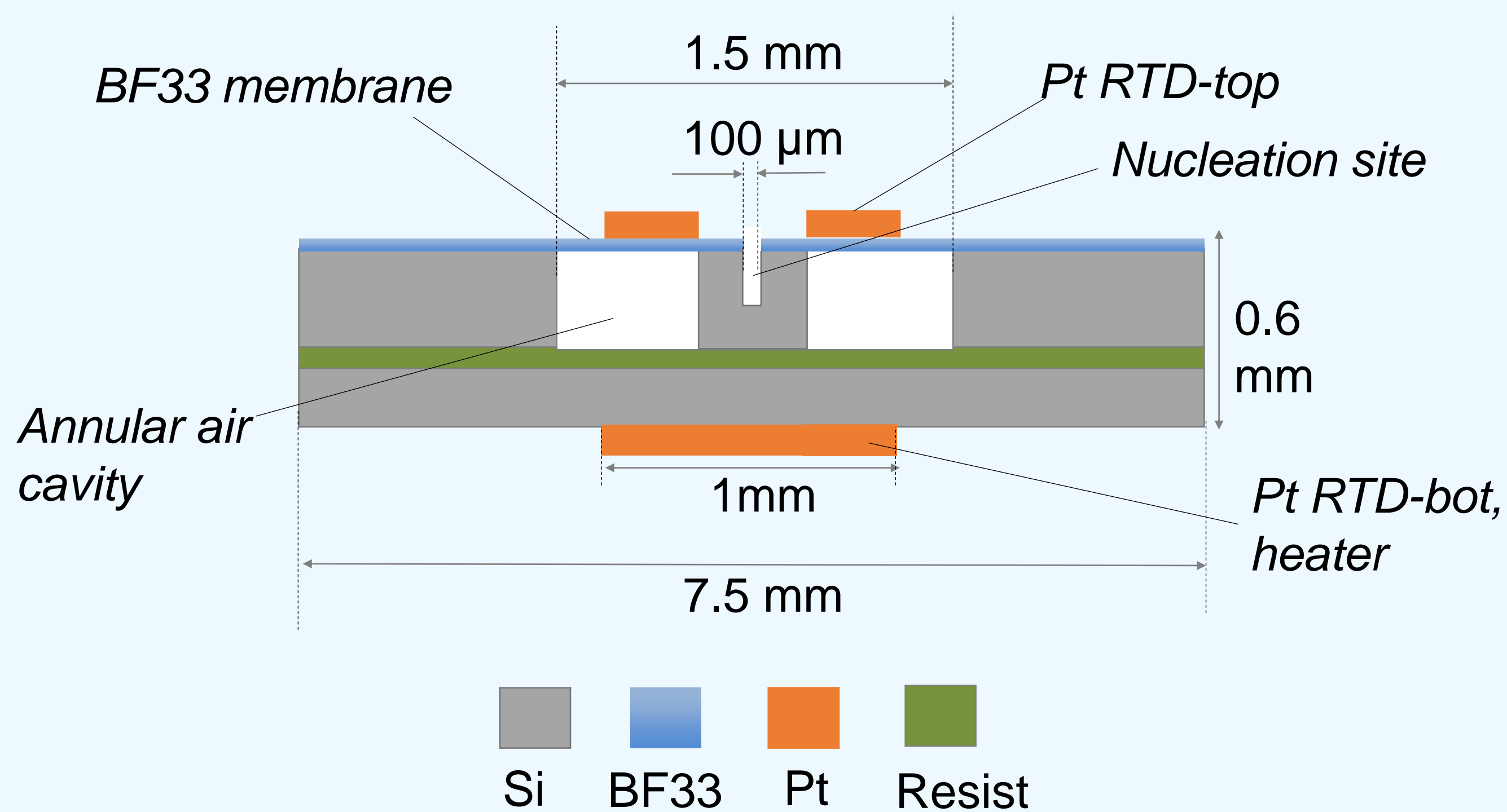
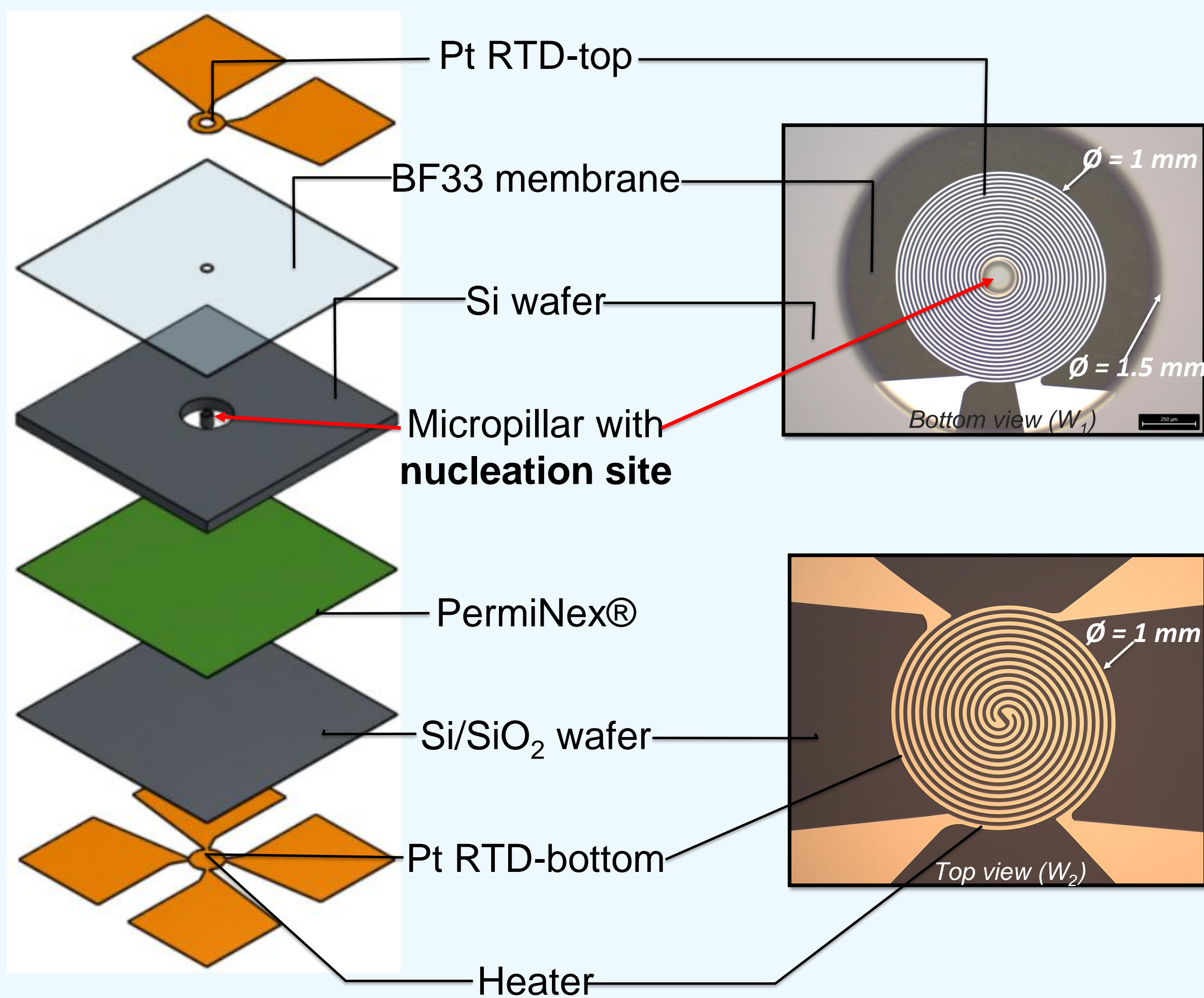

## 3. DYNAMIC CHARACTERISATION

a. Radiative

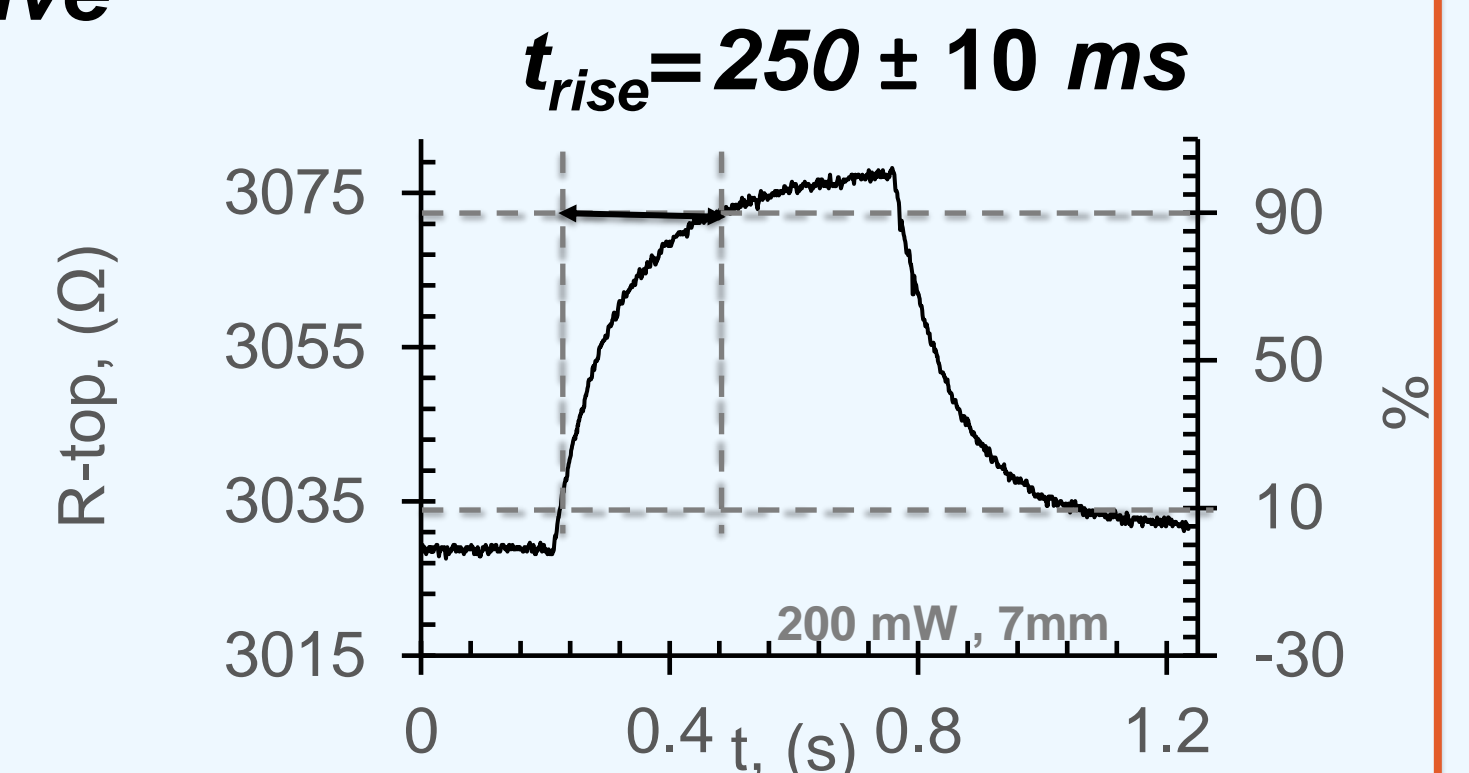
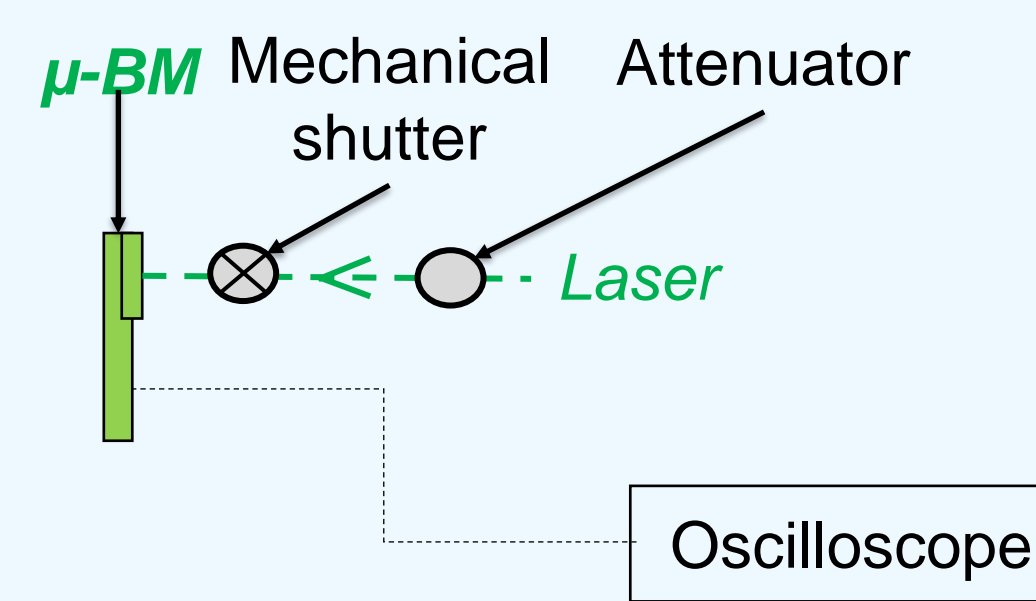

b. Convective (air)

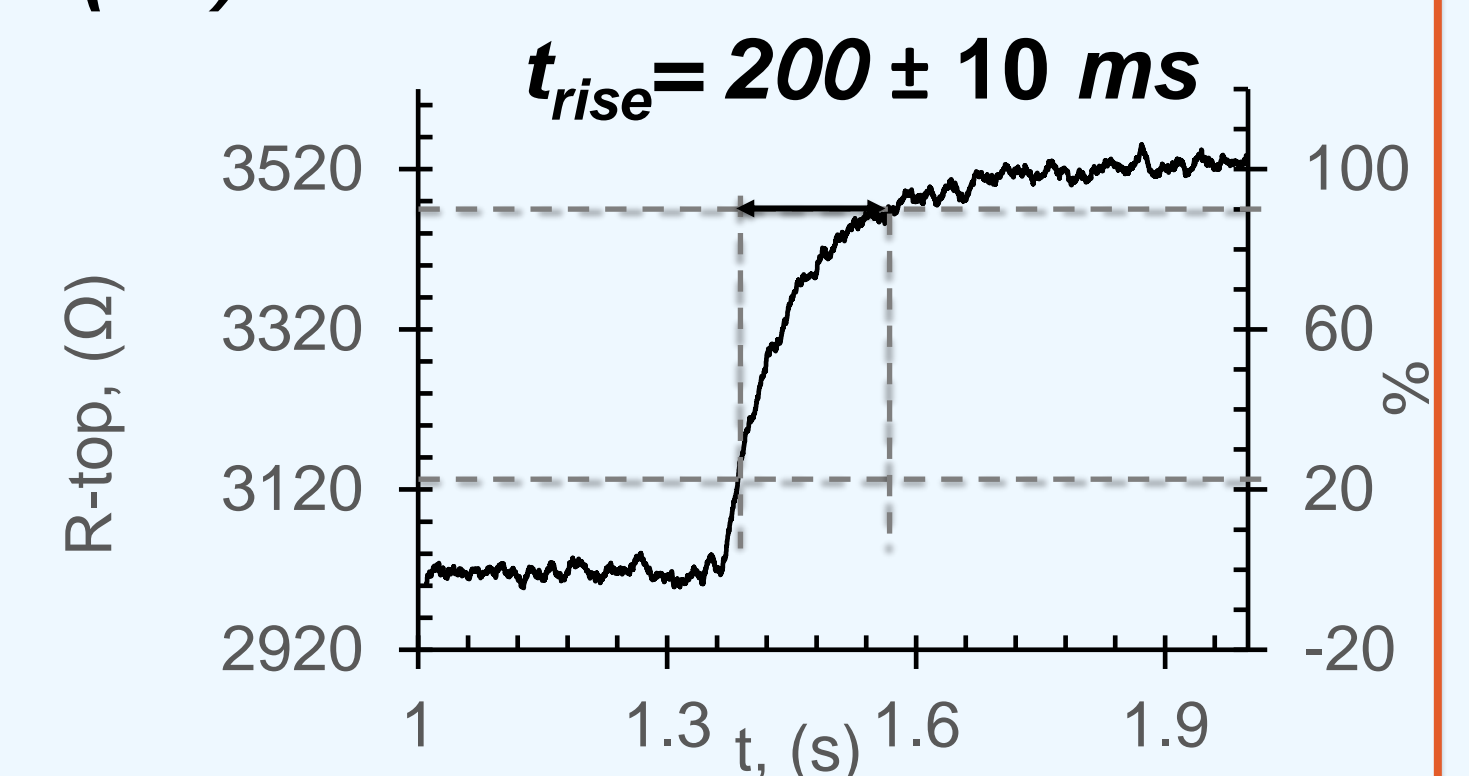
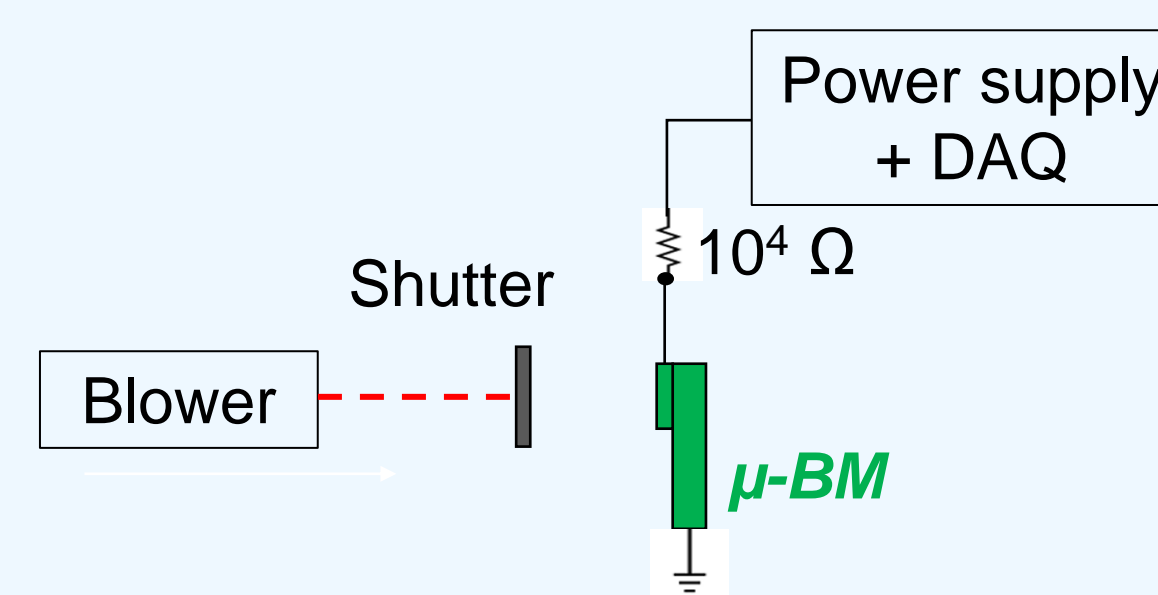

c. Droplet

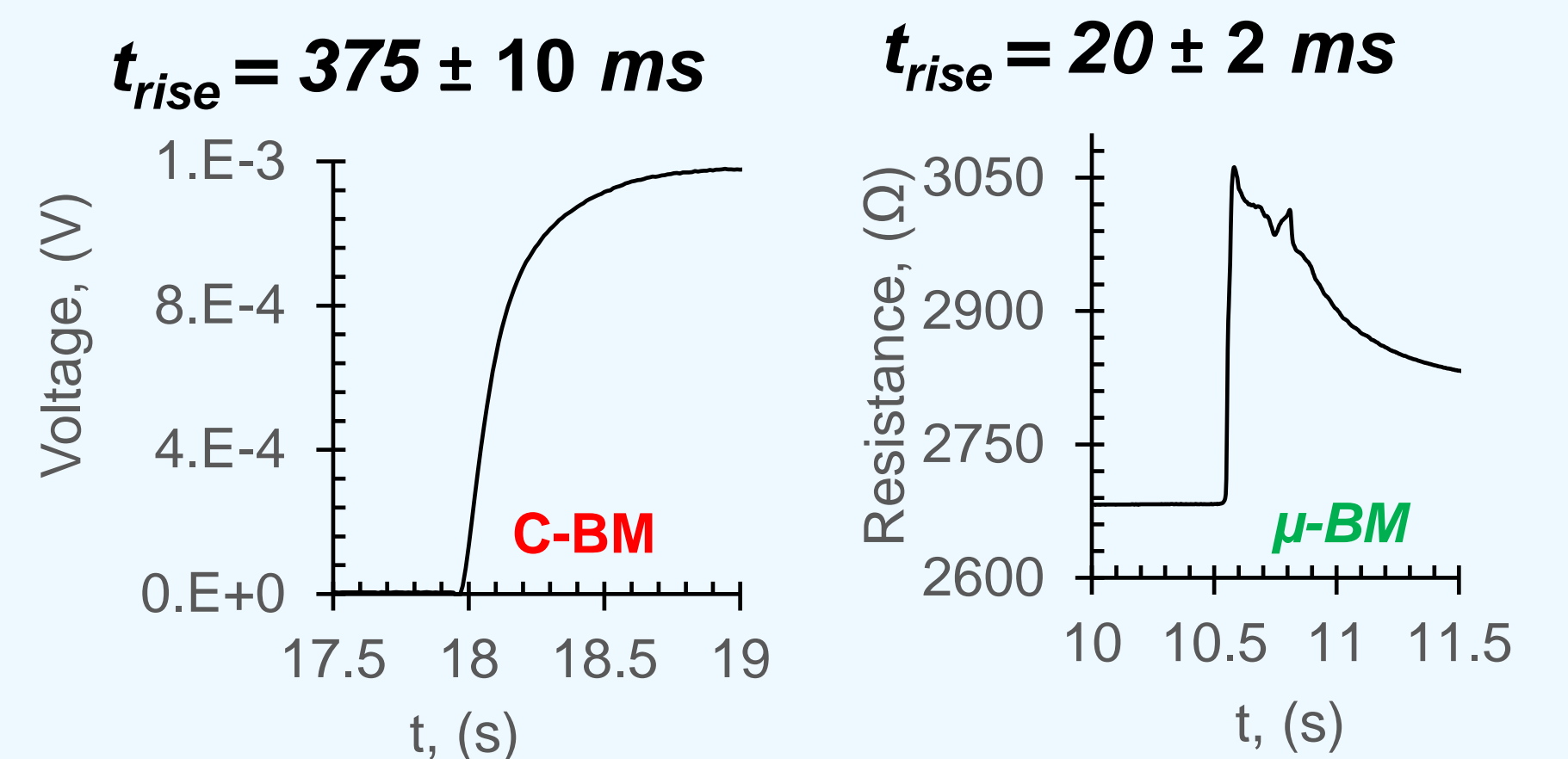
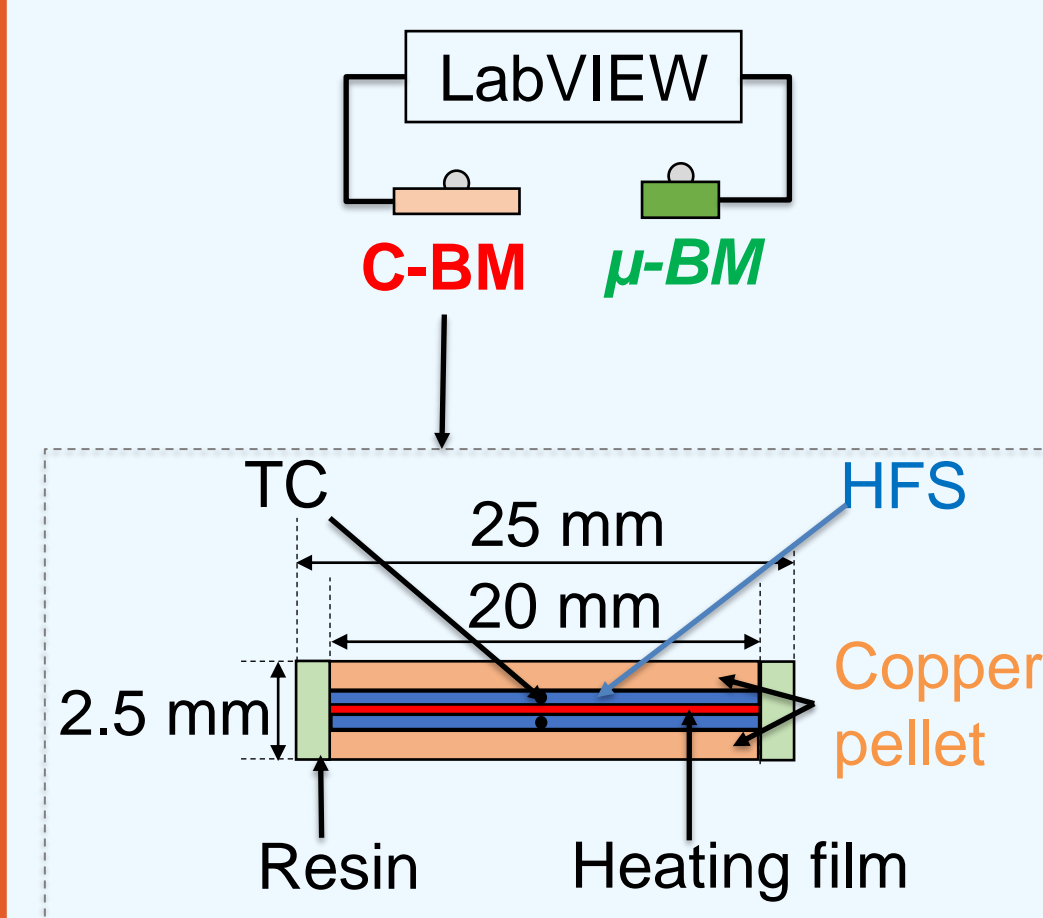

d. Pool boiling

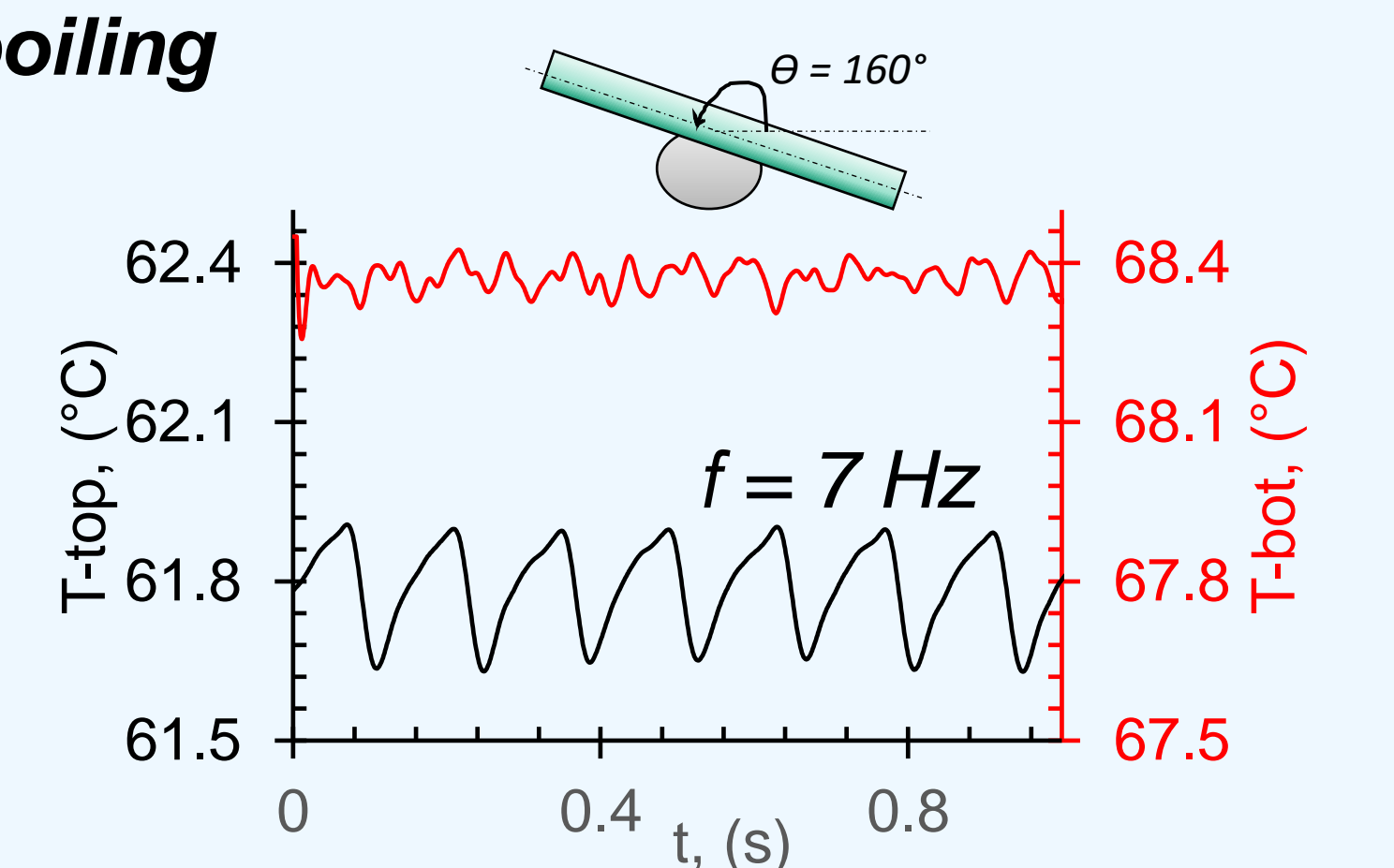
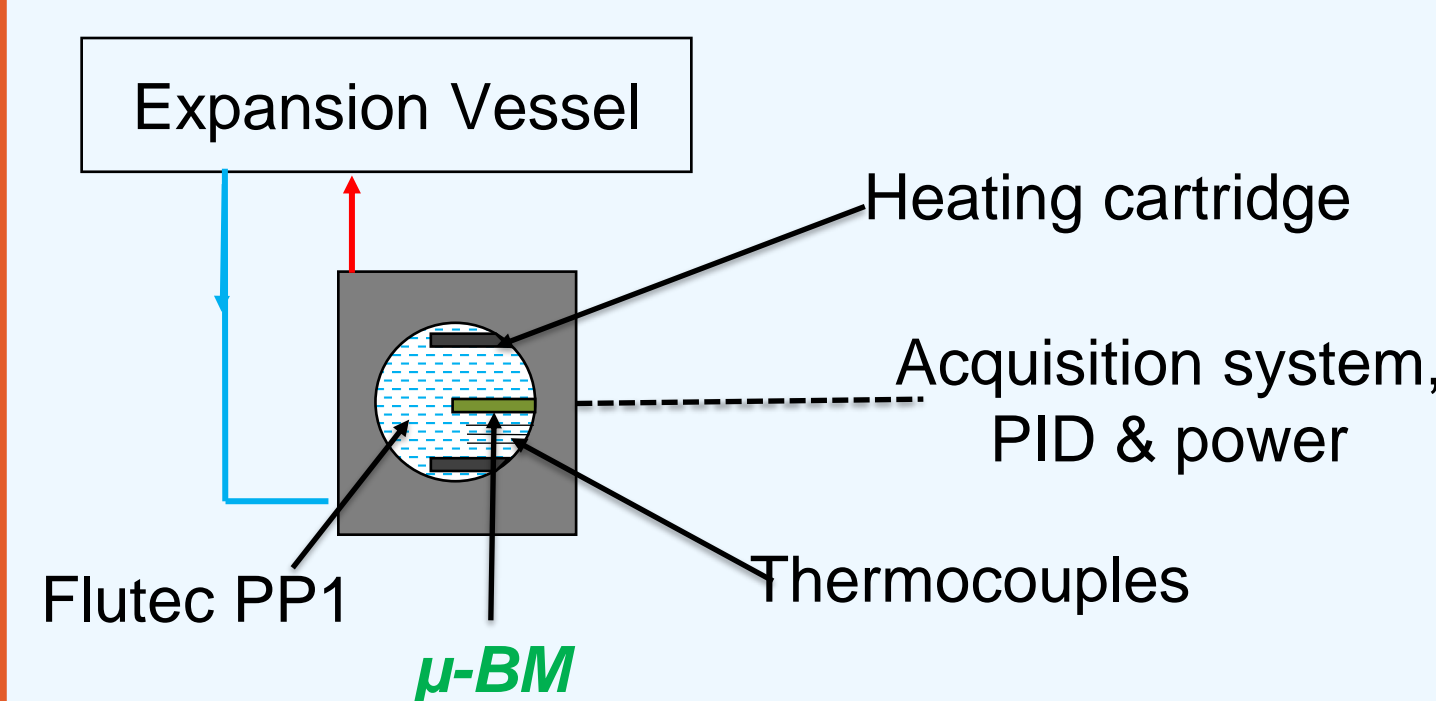

	Boiling meter	Parameter studied	Value
<b>Radiative</b>	$\mu$ -BM	avg, $t_{rise}$ (ms)	215 ± 10 to 425 ± 10
<b>Convective</b>	$\mu$ -BM	avg, $t_{rise}$ (ms)	200 ± 20
<b>Droplet</b>	$\mu$ -BM	avg, $t_{rise}$ (ms)	25 ± 10
	C-BM	avg, $t_{rise}$ (ms)	375 ± 10
<b>Pool boiling</b>	$\mu$ -BM	f, (Hz) ( $\theta = 180^\circ \rightarrow 0^\circ$ )	0.5 to 26.2

## CONCLUSIONS & PERSPECTIVES

- Successfully developed a fully functional micro-boiling meter ( $\mu$ -BM) with an **80% fabrication success rate**.
  - $\mu$ -BM showed **rapid thermal response (~25–425 ms)**, achieving **10–20x faster performance** than the commercial boiling meter (C-BM).
  - Pool boiling** :  $\mu$ -BM successfully **captured single bubble dynamics** over the full tested range (**0.5–26.2 Hz**), while (C-BM) failed beyond **5–6 Hz**.
- The  $\mu$ -BM provides the **speed and reliability** required for next-generation pool boiling research.

**Perspectives :**

- Heat flux calibration of the  $\mu$ -BM for quantitative thermal measurements.
- Systematic pool boiling experiments under wider operating conditions.