

FLOW VELOCITY INVESTIGATION BY PARTICLE IMAGE VELOCIMETRY IN SUPERSONIC AIR EJECTOR

Ala Bouhanguel^a, Philippe Desevaux, Yannick Bailly and Laurent Girardot

FEMTO-ST, Energy Department, University of Franche-Comte, Belfort France

aala.bouhanguel@univ-fcomte.fr

Keywords: PIV; CFD; Ejector; Shock train

Abstract. Ejectors are devices usually made of two convergent/divergent coaxial nozzles which are used to convert pressure energy into kinetic energy. These devices involve very complex phenomena which strongly affect their performance. Flow visualization methods are often used to provide precious information as for the nature of the flow within the ejectors and the comprehension of the physical phenomena encountered. Unfortunately, the visualization methods used successfully until now in these systems are primarily qualitative techniques. Some attempts at quantitative flow visualization by Particle Image Velocimetry have been carried out in quite specific applications but with mitigated results due to the complicated conditions of investigation. The objective of this paper is to present an attempt at PIV measurements in a supersonic air ejector. Several ejector operating conditions and flow seeding **methods** are taken into consideration. The velocity fields obtained are compared with CFD simulations of the flow and allow the rigorous validation of numerical models.

Introduction

A supersonic ejector is a simple device used to convert pressure energy into kinetic energy. It consists of two coaxial converging/diverging nozzles: the primary nozzle is designed to deliver a supersonic jet which sucks and entrains a secondary flow along the mixing chamber of the secondary nozzle. Supersonic ejectors are employed in many applications: vacuum pump, ejector-compressor fluids separator, jet propulsion thrust augmentation . . .

Generally, experimental studies on these devices are focused on global parameters measurement; such as primary and induced flow rates or motive and aspiration pressures. However, supersonic ejectors involve very complex phenomena (interaction between supersonic and subsonic flows, shocks, mixing, instabilities, possible condensation . . .) which strongly affect their performance.

A detailed study of the flow, by measurement of local pressure or velocity for example, is sometimes considered but proves very delicate to implement in particular in the case of supersonic flows with shocks. The visualization of the flow represents an interesting alternative to these measurement techniques by giving access to very precious information related to the nature of the flow within the ejectors and the comprehension of the physical phenomena encountered [1, 2]. Unfortunately, the visualization methods used hitherto (laser tomography, schlieren) in these systems are primarily qualitative techniques. Some attempts at quantitative flow visualization by particle image velocimetry have been carried out in quite specific applications [3, 4] and [5, 6] with mitigated results due to the complicated conditions of investigation (high flow velocity, quality of flow seeding). PIV measurements in a gas ejector have been successfully achieved but only in the subsonic operating regime [7].

The purpose of this study is to present the first results of PIV measurements obtained in our laboratory on a supersonic air ejector. Several ejector operating conditions (with or without secondary flow entrainment) are studied. Different flow seeding methods (natural seeding by condensation microdroplets, artificial tracers added into the secondary flow) were tested. The results obtained are compared with CFD simulations of the flow and allow the rigorous validation of numerical models.

Experimental configuration

The tested ejector is formed of two converging/diverging coaxial nozzles (Fig.1); the primary flow is accelerated through the primary nozzle to supersonic velocity at its exit, producing the suction of the secondary air flow. The sucked air enters through three inlet holes which are arranged at 120° to each other around the settling chamber. The primary and secondary flows then interact in the constant area mixing chamber. The primary/induced air mixture is finally discharged into the surrounding atmosphere. The main ejector dimensions are shown in Fig.1; the primary Laval nozzle is designed to produce a supersonic flow with an exit Mach number of 2.3. The ejector throat-area ratio, defined by the ratio between the radial section of the mixing tube and the throat section of the primary nozzle, is equal to 9. It may be noted that during experiments, the ejector can operate with induced flow (free entrainment condition) or without secondary flow (vacuum operation).

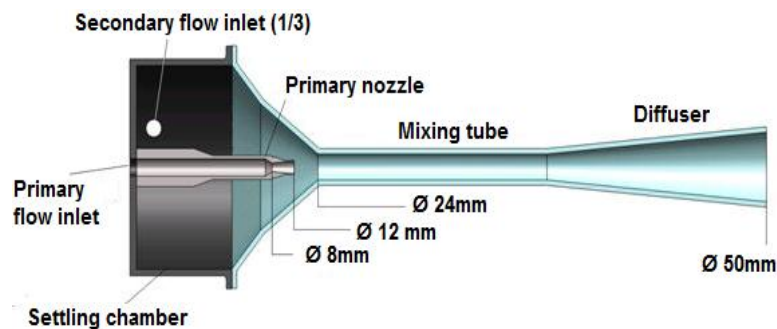

Fig. 1: Ejector configuration

The velocity measurements in the ejector flow are performed by Particle Image Velocimetry. PIV is an optically based measurement technique used to obtain flow velocity distribution by tracking the motion of particles present within the flow. The basic principal of operation involves illuminating a plane of interest with a laser light sheet and using a synchronized camera to capture the change in location of particles within the laser light plane [8].

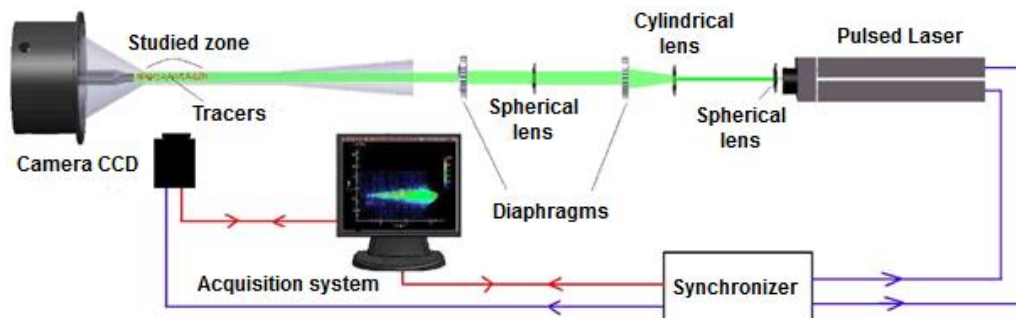

Fig. 2: PIV experimental arrangement

The PIV experimental arrangement (Fig.2) consists of a double cavity laser emitting at $\lambda = 532$ nm wavelength for about 200 mJ of nominal energy and about 9 ns of pulse duration. A set of optical lenses is used to transform the laser beam into a light sheet (with a constant width slightly inferior to the mixing chamber diameter) reflected in the upstream direction along the ejector axis. The viewing direction is perpendicular to the flow axis. A Laser Pulse synchronizer is used to automate the control of the timing between laser pulses and PIV camera. It permits the acquisition with only 200 ns of temporal interval between each pair of images.

Furthermore, two seeding methods are used during our experiments. The first method consists in using natural tracers formed within the flow. These tracers are water microdroplets issued from the condensation of the moisture present in the air feeding the ejector. A previous study [9] has detailed the mechanisms of formation of these microdroplets and has shown that the mean diameter of these

droplets does not exceed $0.1 \mu\text{m}$. The second seeding method uses artificial tracers (i.e. DEHS particles of about $0.3 \mu\text{m}$ mean diameter) which are added into the secondary flow.

Results and discussion

PIV measurements are compared to computational results predicted by 2D axisymmetric simulations of the flow [2, 10]. The steady state Navier Stokes equations were solved using the pressure-based solver with pressure-velocity coupling and second order discretization scheme. Turbulence was modeled using the realizable $k\text{-}\epsilon$ model.

The first results presented in this study concern the ejector operating with free entrainment of secondary flow. Fig.3 and Fig.4 compare results obtained experimentally by PIV and numerically by CFD for a primary stagnation pressure $P_1 = 4 \text{ bar}$. Visualization area covers a distance of 80 mm located in the entry of the mixing tube. It may be noted that the vertical line which is observed on the PIV velocity fields (around the x -abscissa 130 mm) is a parasite light reflection on the transparent surface of the mixing tube. The experimental and numerical velocity fields in Fig.3 both show the formation of a shock structure (also called shock train) composed of a series of oblique shocks, which occurs at the exit of the primary nozzle and interacts with the secondary flow along mixing tube. This shock train is characteristic of a mixed flow regime: the primary jet is supersonic at the primary nozzle exit and the induced flow remains subsonic along the mixing tube.

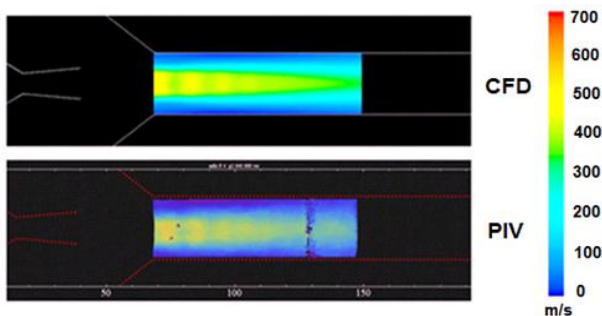

Fig. 3: Comparison of PIV and CFD velocity fields for primary pressure $P_1 = 4 \text{ bar}$

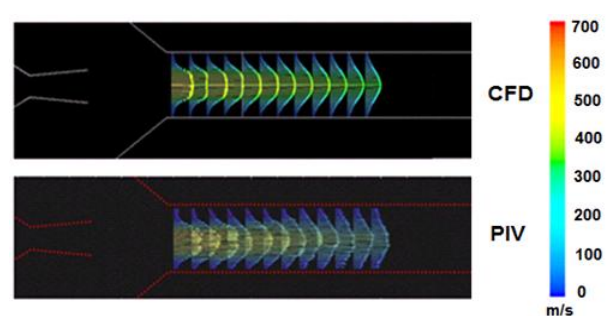

Fig. 4: Comparison of PIV and CFD vectors for primary pressure $P_1 = 4 \text{ bar}$

PIV and CFD visualizations obtained under these operating conditions are in good agreement, especially concerning the number and the location of shocks. These findings are supported by the velocity vectors representation given in Fig.4. They show the very good agreement in the velocity values between PIV and CFD. Nevertheless, PIV measurements show a slight asymmetry in the velocity profiles which is not observed in the numerical results. This difference can be explained by the fact that the CFD simulations use a 2D axisymmetric stationary model which is unable to predict the instabilities caused by the interaction between the two primary and secondary flows.

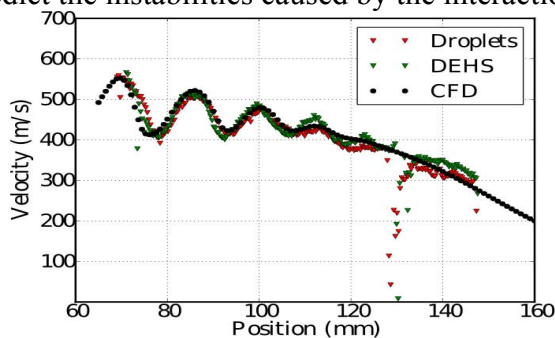

Fig. 5: Evolution of the axial velocity in the mixing tube (with induced flow; $P_1 = 4 \text{ bar}$)

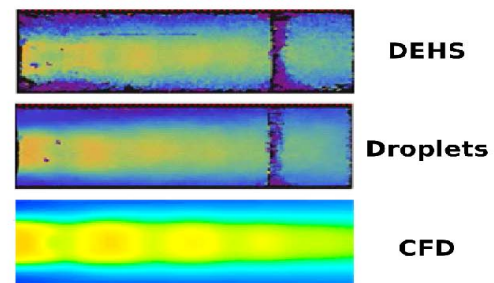

Fig. 6: Comparison of velocity fields (with induced flow; $P_1 = 4 \text{ bar}$)

Fig.5 and Fig.6 compare results obtained using different flow seeding methods. Fig.5 shows a good agreement between the evolutions of axial velocity measured using natural and artificial tracers, especially regarding the number and the location of shocks. PIV measurements appear to be

independent of the flow seeding method and consistent with CFD results. On the other hand, visualizations of the velocity field (Fig.6) highlight a better visual quality obtained with natural flow seeding. This can be explained by a higher number of natural tracers and by their light scattering mode. Indeed, a previous study has shown that the water microdroplets formed by condensation within the flow have a mean diameter which does not exceed $0.1 \mu\text{m}$ and therefore are small enough to scatter in the Rayleigh regime [1].

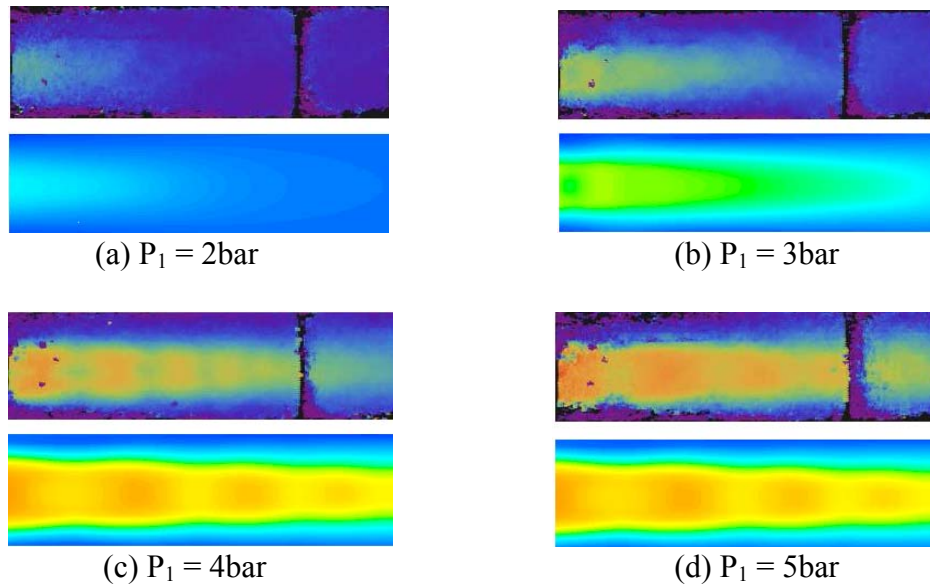

Fig. 7: Evolution of velocity fields with primary pressure P_1

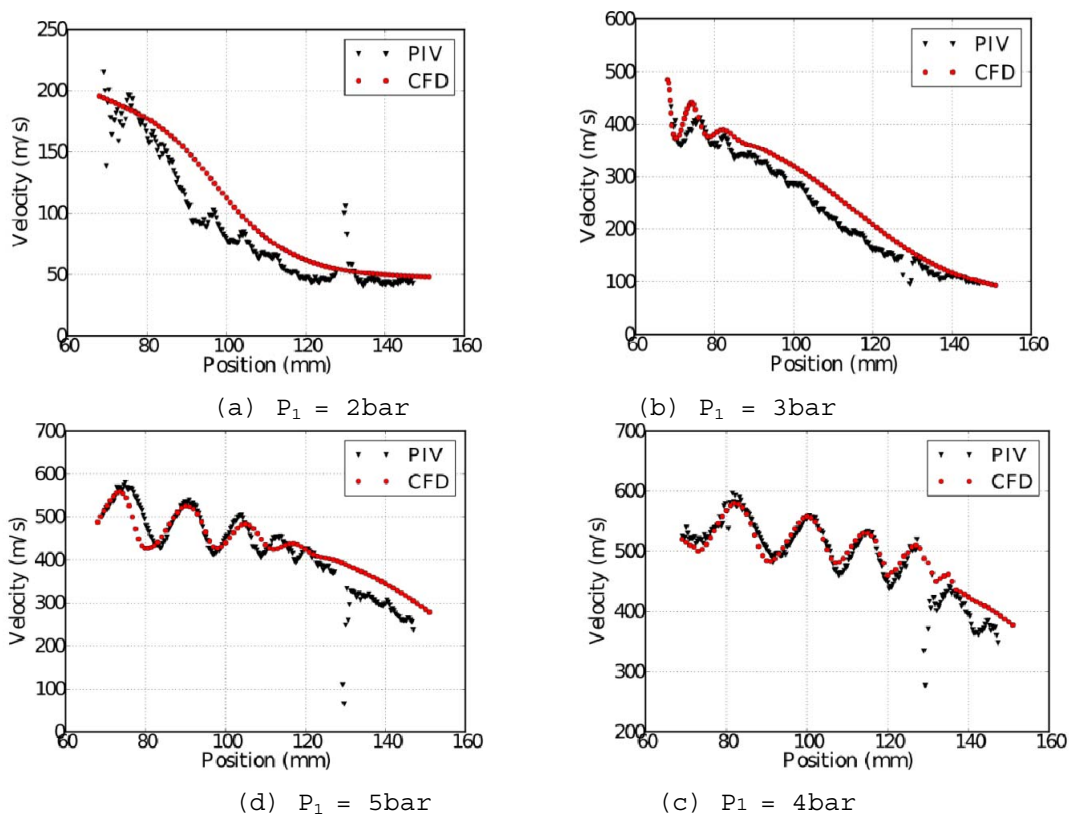

Fig. 8: Axial velocity evolution with primary pressure P_1

The second part of results concerns the ejector operating without induced flow and more particularly the evolution of the flow pattern with the primary stagnation pressure P_1 . Fig.7 compares the velocity fields obtained by PIV and CFD for four values of P_1 . For the lowest pressure

tested ($P_1 = 2$ bar), no shock is observed in the mixing tube entry. The primary pressure must reach a value of 3 bar to give rise to the first shock. Then, we can clearly observe the development of the shock structure with increasing the primary stagnation pressure ($P_1 = 4$ bar and $P_1 = 5$ bar).

Fig.8 presents the evolutions of axial velocity in the mixing tube entry for four values of primary pressure. It may be noted once again a very good coherence between the velocity measurements by PIV and the CFD results. The velocity values are close and the shift of the shocks position is very weak. The first figure, relative to primary stagnation pressure $P_1 = 2$ bar, confirms that the pressure recovery process is achieved without formation of shocks in the mixing tube. This is consistent with the nozzle flow theory that predicts the unchoking of the supersonic flow in the primary nozzle divergent. First shocks of weak intensity occur for a pressure $P_1 = 3$. The shock train is fully developed as soon as one imposes a stagnation pressure higher than 4 bar. The axial velocity distributions obtained by PIV and by CFD are in good agreement for the high primary pressures. The difference between measured and calculated velocities does not exceed 5 %.

Conclusion

This study presents first velocity measurements using Particle Image Velocimetry obtained on a supersonic air ejector. For all the ejector operating conditions considered in this work, the comparison of the measurements with the velocity fields calculated by CFD is very satisfactory despite the complexity of the flow studied. Results are also consistent with the theory of supersonic flow in ejectors, mainly for the shock train theory. Therefore, the PIV technique proves to be a very interesting tool for the validation of CFD simulations in supersonic ejectors. Two flow seeding methods (using natural and artificial tracers) have been tested and have given similar results.

PIV measurements can complement pressure measurements and provide more information than conventional laser tomography visualizations. A more complete investigation of the flow in the ejector, consisting in extending the size of the study zone and applying the PIV technique to other flow regimes (such as the fully supersonic regime where both primary and secondary flows are supersonic), is in progress.

References

- [1] P. Desevaux: *Optics and Lasers in Engineering*, volume 35, (2001), p. 317
- [2] A. Bouhanguel, P. Desevaux and E. Gavignet: *International Journal of Refrigeration*, volume 5,(2011)
- [3] M. Havermann, J. Haertig, C. Rey and A. George: in: *Particle Image Velocimetry*, volume 112, Springer, Heidelberg, Berlin (2008), p. 429–443
- [4] P. Gnemmi, C. Rey, J. Srulijes and F. Seiler: *Congrès Francophone de Techniques Laser*, volume 5, (2011)
- [5] A. Guerriero: *PhD thesis*, INSA Toulouse (2008)
- [6] J. Ishimoto: *Cryogenics*, volume 49, (2001), p. 39
- [7] P. Dolejš: *Journal of Applied Science in the Thermodynamics and Fluid Mechanics*, volume 5 (2011)
- [8] M. Raffel, C. Willert and J. Kompenhans: *Particle Image Velocimetry*, Springer (2007)
- [9] P. Desevaux: *Canadian Journal of Chemical engineering*, volume 79, (2001), p. 273
- [10] P. Desevaux, T. Marynowski and M. Khan: *International Journal of Turbo & Jet-Engines*, volume 23, (2006), p. 173