

COMPRESSION MOULDING OF COMPLEX PARTS FOR THE AEROSPACE WITH DISCONTINUOUS NOVEL AND RECYCLED THERMOPLASTIC COMPOSITE MATERIALS

N.Eguémann^{1,2*}, L.Giger^{1,2}, M.Roux², C.Dransfeld², F.Thiébaud³, D.Perreux³

¹ Cross Composite AG, Steckborn, Switzerland

² Institute of Polymer Engineering, FHNW, Windisch, Switzerland

³ Laboratoire de Mécanique Appliquée, UFC, Institut FEMTO-ST, Besançon, France

* Corresponding author (nicolas@crosscomposite.ch)

Keywords: *discontinuous, cradle to cradle, thermoplastic, compression moulding, complex*

1. General Introduction

Major structures of modern aircrafts such as the long range types from Boeing: 787[1] and from Airbus: the A350XWB [2], are mostly manufactured from carbon-fibre-reinforced polymers (CFRP). In these CFRP primary structures, constituted of skins and reinforcing profiles, hundreds of complex metallic load introduction elements such as brackets, hinges or fittings are attached. Those numerous components are actually remaining metallic, but complex metallic load introduction elements have several drawbacks in aerospace applications. Aluminium parts integrated within aircraft or rotorcraft CFRP airframes have to be mounted with several cost-intensive protections against galvanic corrosion, as shown in Figure 1.

The use of steel for this kind of application adds an increasing weight penalty, while the use of titanium results in high production costs [3] and the need for a secured supply-chain [4].

To best comply with the latest EU regulations, such as the Waste Framework Directive [5] and the Directive on End Of Life Vehicles [6], thermoplastic CFRP (TP-CFRP) will be preferred to thermosets CFRP (TS-CFRP). TS-CFRP, due to their cross-linked matrix, cannot be moulded again in comparison to TP-CFRP that can be easily remelted [7]. A full life cycle assessment performed on a complete helicopter door also showed the global superiority of TP-CFRP over TS-CFRP [8].

In order to use TP-CFRP for this specific type of complex application, Toray Industries, Inc. conducted early research that, in 1990, led to a patent[9] clearly describing how strip pieces (chips) made of chopped thermoplastic pre-impregnated unidirectional fibres (UD tapes) are distributed in a plane parallel to the surface cavity of a tool, heated and consolidated under pressure. The length of the chips is defined to be long enough to obtain mechanical properties similar to those of a quasi-isotropic laminate while being short enough to maintain the advantage of fitting well. Meanwhile, very few studies have been published reporting the mechanical properties of this specific kind of material, which is the goal of the present work.

The application case delivered by Eurocopter Germany GmbH is a CNC-machined steel hinge from the rotorcraft model EC 135 (Figure 2), weighing 135 grams and mounted on a CFRP door structure.

The overall part dimensions are 112mm x 42mm x 22.5mm (Figure 3). The steel hinge has to withstand a static maximal load case of 2.172kN for a perpendicular bearing force.

An original steel hinge was tested using a specially designed jig (Figure 4) at a displacement rate of 1mm/min. The resulting curve (Figure 5) shows typical elasto-plastic behaviour with an elastic zone up to 3kN and plastic zone up to the ultimate failure at 8kN. For security reasons and maintenance convenience, the new TP-CFRP hinges, which retain similar geometrical interfaces and functions, will have to withstand the above-mentioned critical load and

show the same progressive failure behaviour with large plastic deformation as the original steel hinge.

2. Hinge Production

Several types of TP-CFRP materials were selected. They are all constituted of AS4 carbon fibres embedded in a PEEK matrix. Only the fibre length and fibre content may vary according to Table 1 and Figure 6.

While it is easily understandable what kind of materials UD tapes, chopped tapes and injection moulding granules are, we will pay more attention to explaining how “recycled fragments” are obtained. Prior trials to recycle TP-CFRP parts using warm sulphuric and nitric acids or mechanical shredding [3] delivered poor results, pushing us to test another proven technology coming from the mining industry called high-voltage fragmentation. The material to be recycled (in our case, door hinges) is placed in water between an anode and a cathode (Figure 7).

Pulsed electric discharges are applied to the material over a short period, creating pressure waves that lead to the cracking of weak regions (mainly resin-rich areas) in the composite material, generating recycled fragments as shown in Figure 8.

In this specific case, the fragments were obtained by recycling TP-CFRP door hinges produced from 20mm chopped tapes and directly pressed into the mould after drying. So it was possible to demonstrate a real cradle-to cradle recycling process. An extensive testing campaign [10] on coupons helped to determine the properties of the different materials.

The shear web shape was optimised through re-design in order to obtain an I-profile (Figure 9), resulting in a new part weight of 22g (without bearing).

A tooling solution using two sliders and a stamp was developed to obtain the four fixation holes, the bearing sit and the I-profiled shear web moulded into

a net shape (Fig.10). For the hinges produced from chopped tapes, recycled fragments and injection moulding granules, the required amount of material was gravimetrically pre-dosed and placed into the tool.

Then the tool and material were heated above the melting temperature of PEEK (345°C). Once the melting temperature was reached, a 100-bar pressure was applied to the material. Finally, the tool was cooled in a homogeneous way under the glass transition temperature of PEEK (140°C). Then the consolidated part was ejected and ready to be tested. Door hinges were also produced using a more classical laminate approach. Customized preforms were cut from UD tapes and put at the right place in the tool, as shown in Figure 11, with the following ply lay-up:

- Zone 1: UD 0°, spar caps
- Zone 2: +/-45°, shear web
- Zone 3, quasi-isotropic, basis plate

Although the production of laminate-based door hinges is time intensive, it is of general interest to generate a challenging benchmark study.

3. Results

Figure 12 shows representative load-deformation curves for each type of material. We can observe that the hinges produced from injection moulding granules and recycled fragments show brittle failure behaviour. Furthermore, the failure occurs directly in the bearing sit for both material types. Hinges produced with chopped tapes and laminated UD tapes show a tough failure with a large plastic deformation.

The failure occurs exclusively in the shear web. In Figure 13, we can observe the mean ultimate load and corresponding deviation measured for each type of material.

Laminate-based hinges show the best behaviour but, as mentioned before, their production is time consuming and expensive. The hinges produced from 20mm chopped tapes are almost as good as the laminate-based ones but their deviation measured over 5 samples is too high and could be problematic when determining the statistical minimum values, also called A and B values[11].

This type of material is known to be sensitive to statistical size effects [12] and, for this reason, the use of the shortest chips could improve the global behaviour by reducing the deviation. This is exactly what is observed with hinges produced from 10mm chopped tapes, although the measured mean value is a little bit lower. Recycled door hinges only show 15% less strength than the original hinges they were produced from. Although their failure behaviour is not adequate, the cradle-to cradle recycling can be considered as successful with a really low down-cycling effect. Recycled hinges still show a higher ultimate load than hinges produced from injection moulding granules.

4. Conclusion

Hinges produced with 10mm chopped tapes seem to be the best candidates to replace metallic hinges: their production time is short, they are less sensitive to size effects, their failure behaviour is appropriate and a weight gain of 80% could be reached compared to CNC-machined steel hinges.

When computing the allowables based on the values measured on the eight tested samples according to the procedure13 shown in Figure 14, the values in Figure 15 are obtained. We can observe that even the computed minimal statistic A and B values are over the above-mentioned threshold load of 2.172kN. This makes this lightweight alternative also appropriate for critical applications such as aerospace parts.

Acknowledgments

The authors would like to acknowledge Eurocopter Germany GmbH, the Swiss Commission for Technology and Innovation and the School of Engineering of FHNW and its Excellence Programme for supporting this experimental study. The study was

also supported by SUPREM SA through the donation of material.

References

- [1] Marsh, G. Boeing's 787: trials, tribulations, and restoring the dream. *Reinforced Plastics* 53, 16–21 (2009).
- [2] Marsh, G. Airbus A350 XWB update. *Reinforced Plastics* 54, 20–24 (2010).
- [3] Eguémann, N et al. Manufacturing and Recycling of Complex Thermoplastic Parts for Aerospace Applications. in (SETEC, Lucerne, 2012).
- [4] Seiner, H. & Chad Whalen. *The Need for a Secure Titanium Supply-Chain* (2009).
- [5] European Bioplastics, Fact Sheet, Mechanical Recycling, Waste framework Directive, 2008/98/EC, Article 11: Re-use and recycling (2010).
- [6] EU, Brussels. *End of Life Vehicle Directive 2000/53/EC* (2000).
- [7] Pickering, S. J. Recycling technologies for thermoset composite materials – current status. *Composites Part A: Applied Science and Manufacturing* 37, 1206–1215 (2006).
- [8] Parlevliet, P., Pudenz, C. & Weimer, C. *EcoDesigned Thermoplastic Composite Helicopter Airframe Structures*. SETEC, Lucerne (2012).
- [9] Kimoto, Y., Murata, K. & Muraki, T. Thermoplastic composite plate material and products molded from the same (1992). At www.google.com/patents/US5151322.
- [10] Eguémann, N. *Industrial Manufacturing of Parts, Brackets and Fittings in Carbon PEEK Compounds*. Swiss CTi Scientific Report (2012).
- [11] MIL-HDBK-5J, Department of Defense, *Handbook Metallic Materials and Elements for Aerospace Vehicle Structure* (2003).
- [12] Harper, L. T., Qian, C., Turner, T. A., Li, S. & Warrior, N. A. Representative volume elements for discontinuous carbon fibre composites – Part 2: Determining the critical size. *Composites Science and Technology* 72, 204–210 (2012).
- [13] Jean Rouchon. *Certification of Aircraft Composite Structures* (2006).

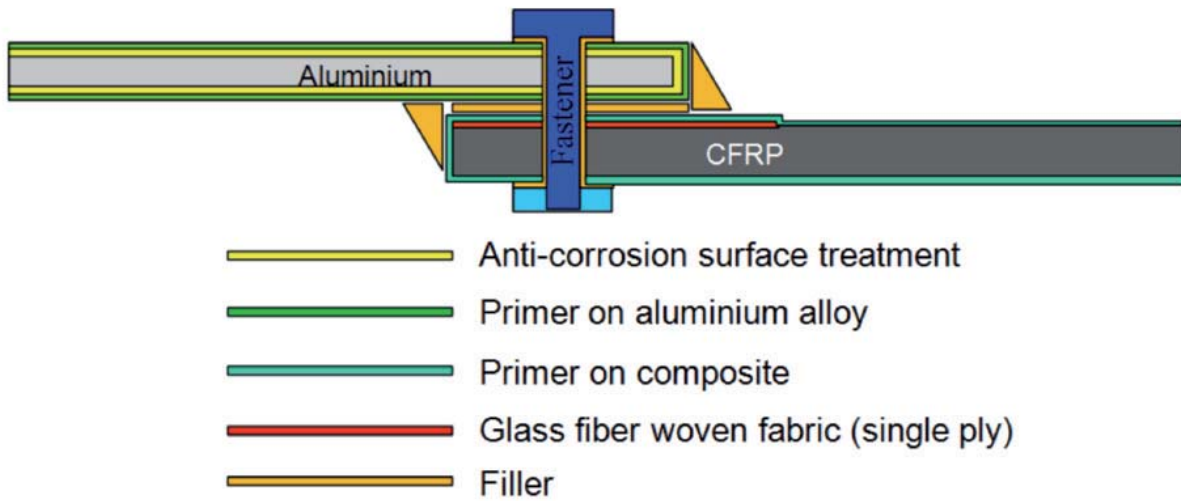

Figure 1 EASA recommended protection against galvanic corrosion



Figure 2 TP-CFRP door hinge and original CNC-machined steel hinge (courtesy of Eurocopter Germany GmbH)

COMPRESSION MOULDING OF COMPLEX PARTS FOR THE AEROSPACE WITH DISCONTINUOUS NOVEL AND RECYCLED THERMOPLASTIC COMPOSITE MATERIALS

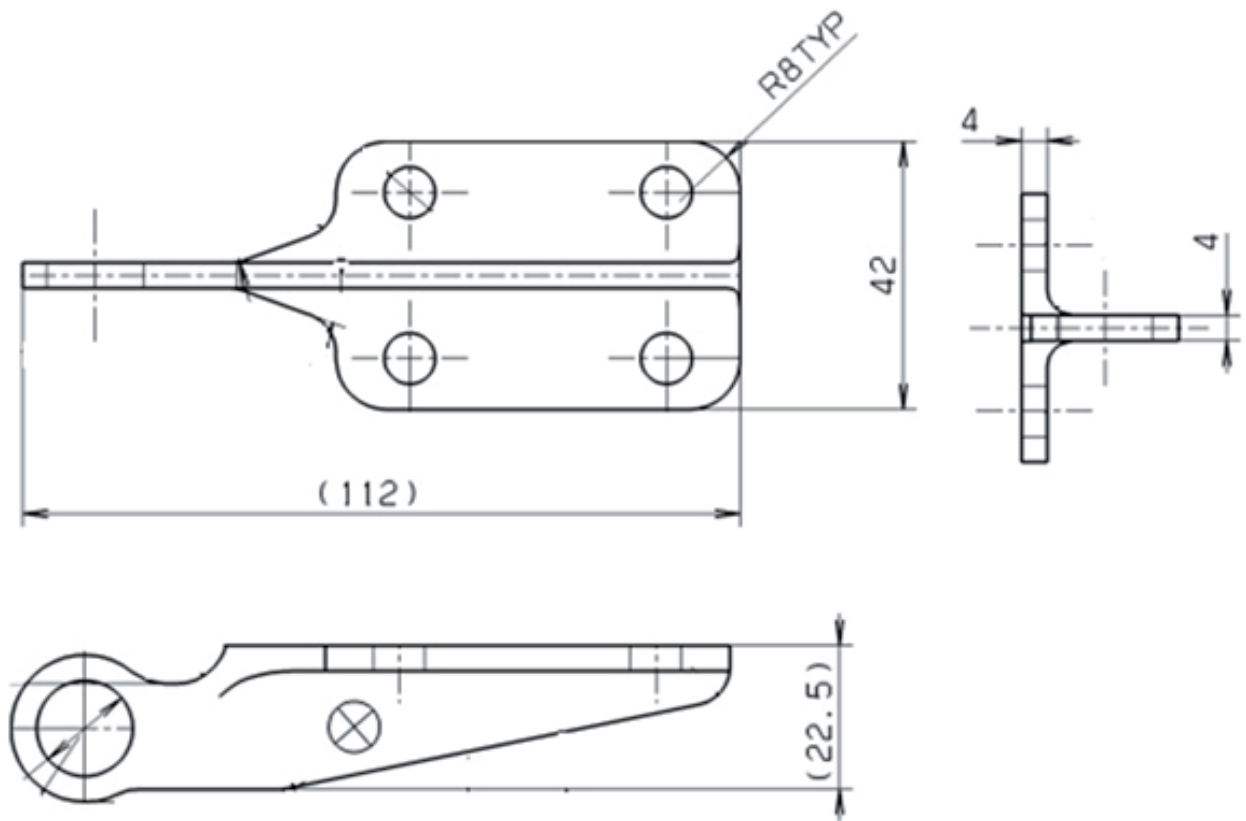

Figure 3 Dimensions of the CNC-machined steel door hinge (courtesy of Eurocopter Germany GmbH)

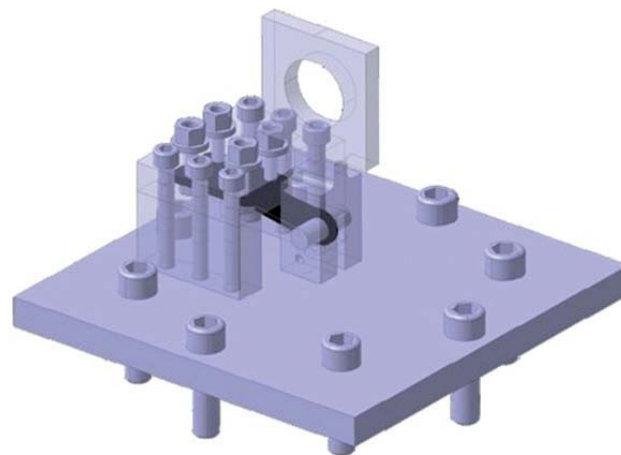

Figure 4 Testing jig

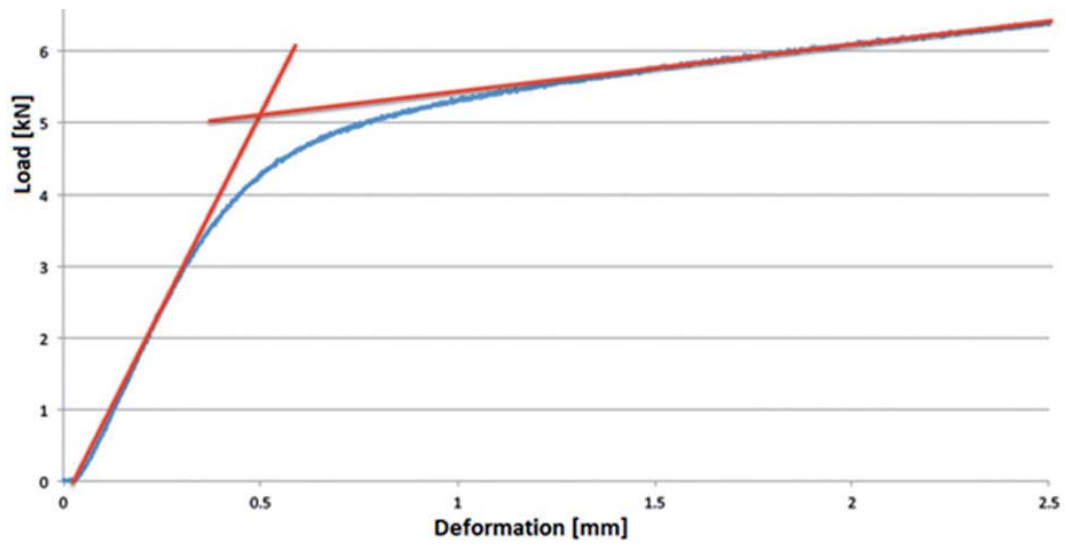

Figure 5 Load deformation curve of the original CNC-machined steel hinge



Figure 6 From left to right, UD tape, 20mm chopped tapes, 10mm chopped tapes, recycled fragments, injection moulding granules

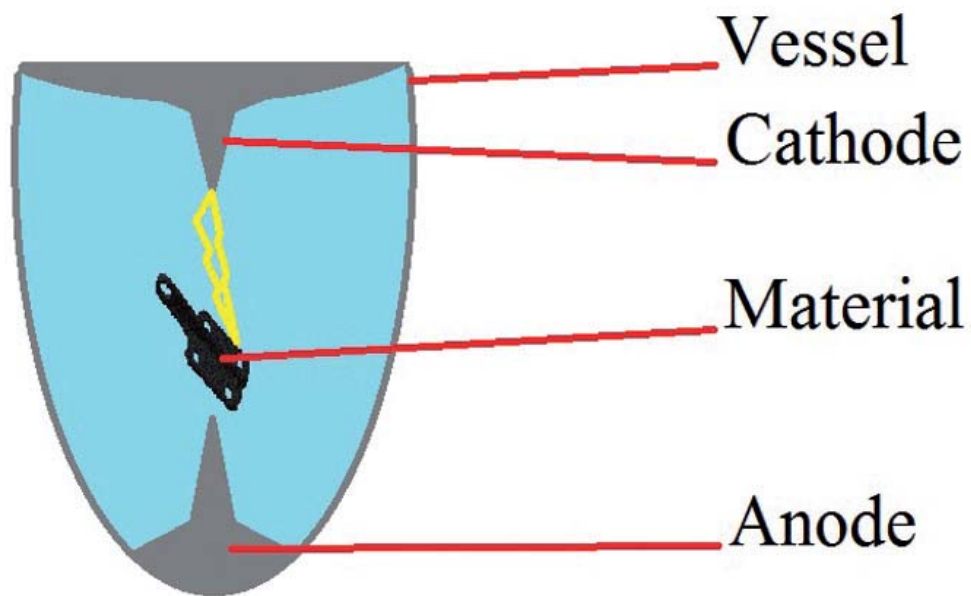

Figure 7 Schematic view of the high-voltage fragmentation process

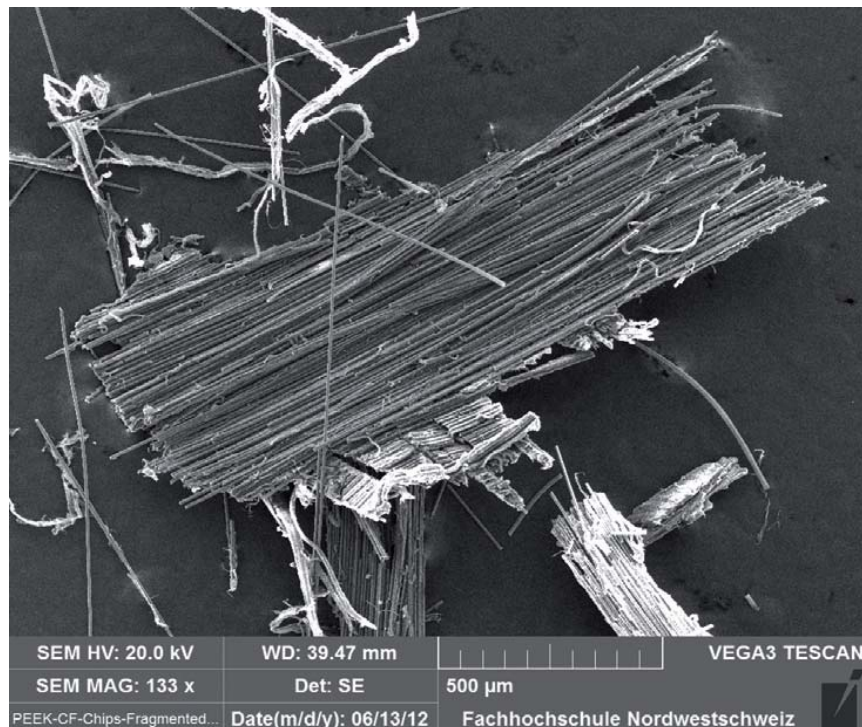

Figure 8 SEM observation of a recycled fragment

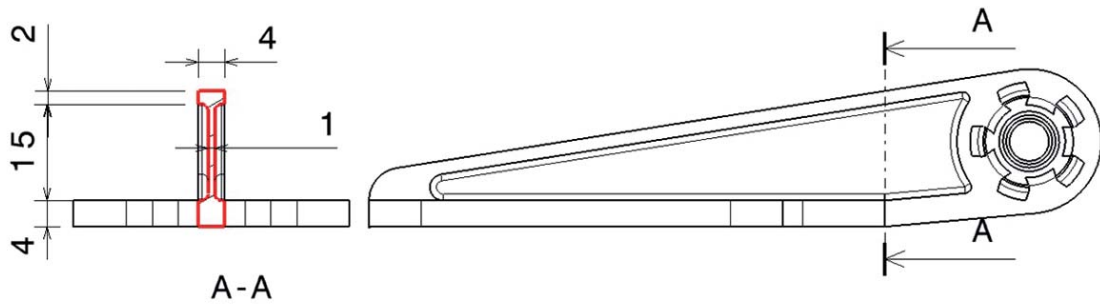

Figure 9 Re-designed TP-CFRP door hinge with I-profiled shear web



Figure 10 Compression moulding tooling solution with sliders and stamp

COMPRESSION MOULDING OF COMPLEX PARTS FOR THE AEROSPACE WITH DISCONTINUOUS
NOVEL AND RECYCLED THERMOPLASTIC COMPOSITE MATERIALS

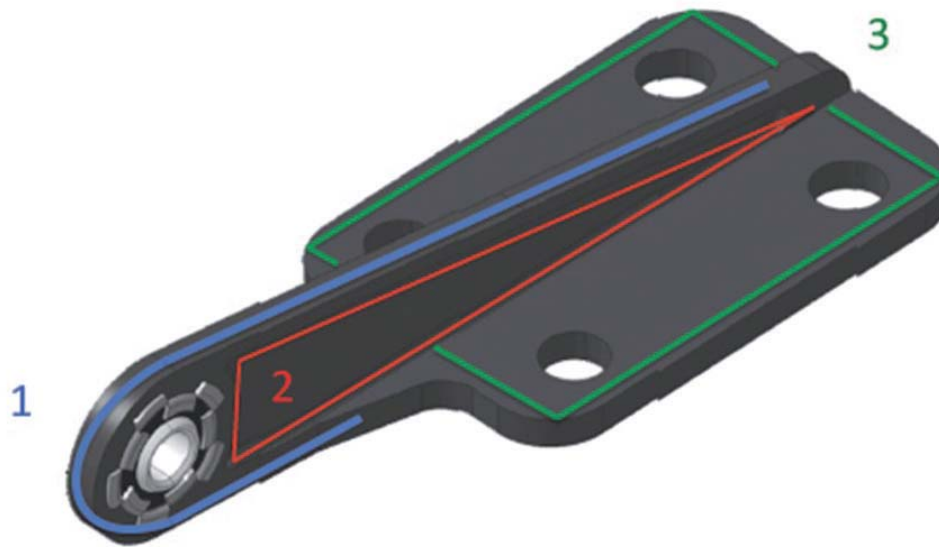

Figure 11 Zone definition for the laminate-based door hinges

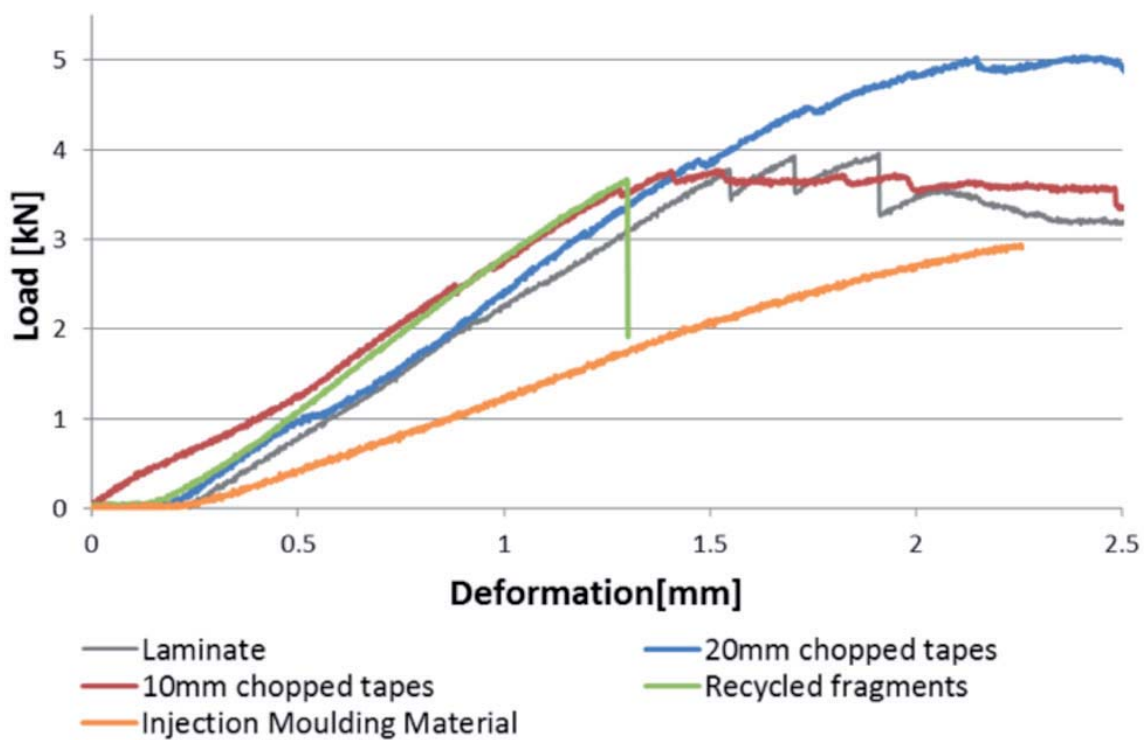

Figure 12 Representative load-deformation curves for each material type

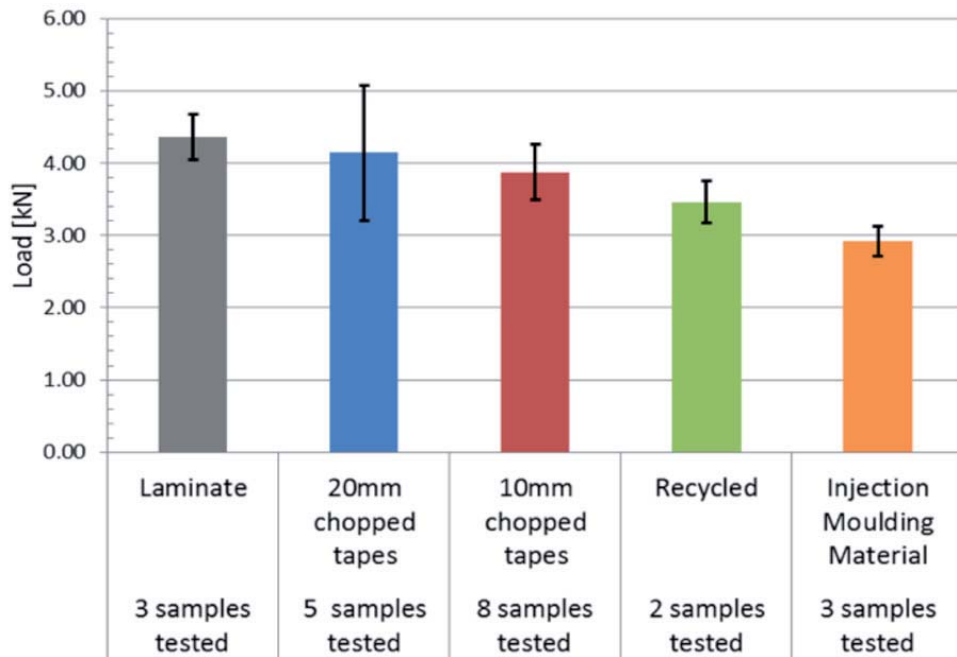

Figure 13 Ultimate load measured for each type of material

Sample Size (n)	2	3	4	5	6	7	8	9	10
kA	37.094	10.553	7.042	5.741	5.062	4.642	4.354	4.143	3.981
kB	20.581	6.155	4.162	3.407	3.006	2.755	2.582	2.454	2.355

X = sample mean based on n observations, S = sample standard deviation

A value = $X - k_A \cdot S$ B value = $X - k_B \cdot S$

Figure 14 Computational procedure for generating allowables [13]

**COMPRESSION MOULDING OF COMPLEX PARTS FOR THE AEROSPACE WITH DISCONTINUOUS
NOVEL AND RECYCLED THERMOPLASTIC COMPOSITE MATERIALS**

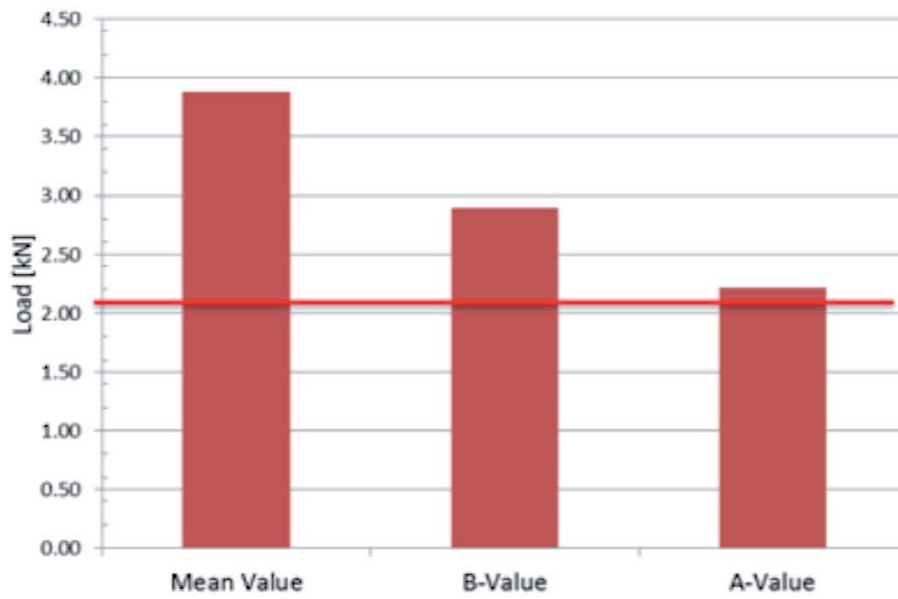

Figure 15 Computed A and B values for hinges produced with 10mm chopped tapes

Table 1 Raw Material Types

material type	volume fibre content	Fiber Length
UD tape	58%	continuous
20mm chopped tapes	58%	20mm
10mm chopped tapes	58%	10mm
recycled fragments	>58%	<10mm
injection molding granules	24%	<1mm